

GENERAL INFORMATION



PRODUCT RANGE

MISSION

For 50 years the Lafert Group have been committing to continuous growth by being the global leading manufacturer of Customised Engineered Electric Motors and Drives with special focus on Industrial Automation, Energy Saving and Renewables.

The Group have developed an excellent ability to adapt the highest quality standards to any specific market demands providing solutions for several applications and OEM requests.

The Lafert Group's range of products is divided in 5 product sectors

ENERGY EFFICIENT Motors, three-phase motors high efficiency, IE2 and premium efficiency, IE3



ENERGY EFFICIENT Motors

CUSTOMISED Motors, single-phase, three-phase and brake motors in special execution



CUSTOMISED Motors

HIGH PERFORMANCE Motors, permanent magnet synchronous motors and generators as well as the relevant drives



HIGH PERFORMANCE Motors

SERVO Motors & Drives, brushless servomotors and drives for industrial automation



SERVO Motors & Drives

LIFT Motors, permanent magnet synchronous gearless machines for elevators



LIFT Motors

PRODUCT RANGE

HIGH PERFORMANCE MOTORS

PERMANENT MAGNET SYNCHRONOUS MOTORS SIGNIFICANTLY REDUCE ENERGY COSTS

High Performance is a range of PM synchronous motors 0.37 kW to 22 kW, with variable speed and equipped with sensorless drives. By combining the technology of both brushless servo motors and AC motors, this range achieves the highest efficiency level IE4 \square Super Premium Efficiency and is specifically designed for its energy saving potential and renewable energy applications.

Permanent magnet technology, very high efficiency, compact design, reduced weight, low operating temperature.



PRODUCT RANGE

SERVO MOTORS & DRIVES

A MODERN AND COMPLETE RANGE FOR INDUSTRIAL AUTOMATION

The range of Brushless Servo Motors is one of the most complete available on the market, with nominal torques 0.30 Nm to 150 Nm. Direct Drive Motors cover torques 10 Nm to 500 Nm.

Thanks to its whole integrated manufacturing process, Lafert is one of the few independent manufacturers of servo motors and can supply a wide range of standard and tailor-made products for Industrial Automation giving excellent flexibility and high level of cost efficiency.

The family of Servo Drives is especially engineering for brushless servo motors and DC motors providing particular versatility and adaptability when designing automated industrial machines.

These products ensure high reliability and are subjected to strict tests in different loads and climatic conditions.

A separate catalogue is available.



PRODUCT RANGE

LIFT MOTORS

GEARLESS MACHINES FOR ELEVATORS

The Lift range allows the manufacturing of systems where the traction machine is inside the elevator shaft, so there is no need for a machine room, with obvious space and cost savings and a more rational layout of the all components.

Permanent Magnet Gearless Synchronous Machines with compact design, reduced energy consumption, low noise level, high comfort and requiring less maintenance. Motors with torque up to 660 Nm for systems with a capacity load up to 1,275 kg, machines with T \times V S \times D Certifications, in compliance with the Specifications EN 81-1 and Lifts Directive 95/16/EC.

A separate catalogue is available.

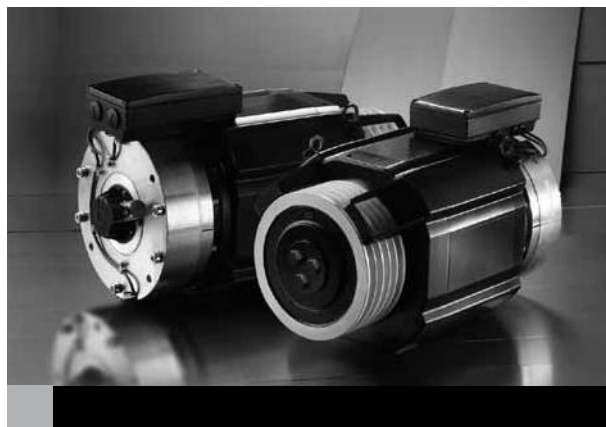

PRODUCT RANGE

CUSTOMISED MOTORS

CUSTOMISATION, OUR CORE BUSINESS

A wide range of Customised Motors with special execution, in order to optimise electrical and mechanical design for particular markets or specific OEM requests.

Single-phase, Three-phase and Brake Motors manufactured ad hoc for non-standard applications according to customer's demands—customised flanges and shafts, special electrical design for each duty request, complete tailor-made design, AC or DC brake coil to fit any applications, solutions to special environmental conditions (Smoke and Heat Exhaust Ventilation, Dust Ignition for Zone 22, Non Sparking Exn).

A separate catalogue is available.

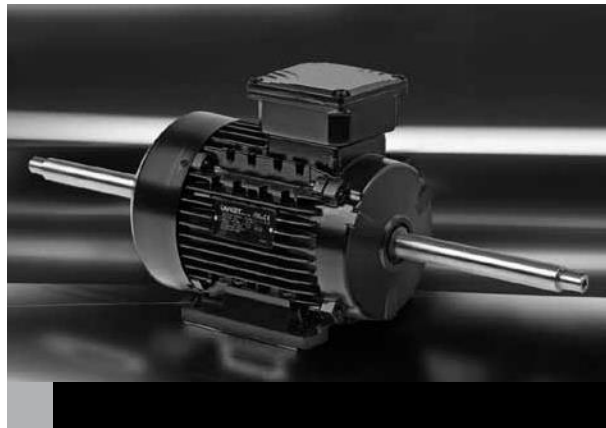

PRODUCT RANGE

ENERGY EFFICIENT MOTORS

HIGH EFFICIENCY, ENERGY SAVING

The range of Energy Efficient Motors has been developed to meet the increasing demand for increased energy efficiency and energy saving products in Europe, North America and Australia after the introduction of directives imposing higher minimum efficiency levels.

IE2
IE3

High Efficiency and Premium Efficiency Three-phase Motors up to 200 kW meeting the requirements of IE2 and IE3 internationally efficiency levels in accordance with IEC 60034-30:2008 and test method IEC 60034-2-1:2007.

ENERGY
UL
US

Motors conforming to the higher efficiency standards for the North American market in accordance with EPA Act Regulation (Energy Policy Act, 1992) and EISA Directive (Energy Independence and Security Act, 2007).

In addition these motors are verified by UL Underwriters Laboratories Inc..

UL | **Energy**
Verified

The range of Energy Efficient Motors from Lafert is the first complete range of IE2 and IE3 motors available to worldwide Industry.

A separate catalogue is available.

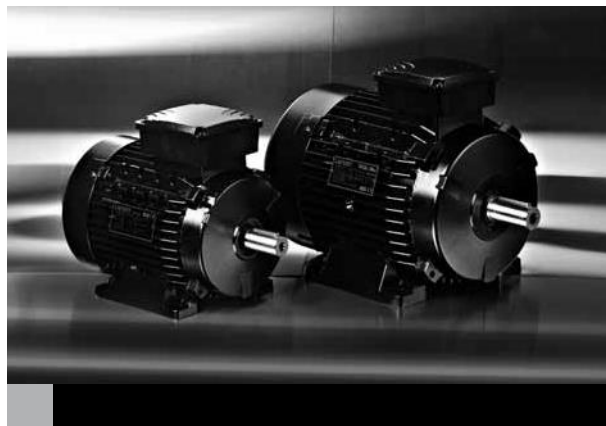

MERGING TECHNOLOGIES

PM SYNCHRONOUS MOTORS SIGNIFICANTLY REDUCE ENERGY COSTS

A new high-performance motor intended for the OEM market that offers significant savings on running costs and space requirements that can be engineered to match customer applications has been introduced by Lafert. Savings on operating costs are substantial since the motor's are far superior compared to standard AC induction motors enables significant frame size reductions plus weight savings.

The new Lafert High Performance motor combines the technology of both brushless permanent magnet servo motors and conventional AC induction motors. The ability to do this is facilitated by the fact the Lafert Group has both servo and AC induction motor knowhow in-house.

By combining these technologies, substantial efficiency advantages over conventional AC induction motors, including IE4, are achieved. The efficiency is superior across the whole speed range.

As with the brushless, permanent magnet servo motors, the rotor of the Lafert HP motor has no losses. Also, stator currents are lower, consequently generating lower losses due to low current demand (Joule effect), the benefit is limited temperature rise for both the windings and bearings. These limited temperature rises can in the right design eliminate the need for a cooling fan and its related losses. Ultimately, the sum of these minimised heat contributions provides higher running speeds and extended bearing life.

The enhanced performance characteristics of the HP motor also permit Lafert to offer smaller frame size solutions and weight savings of around 50%.

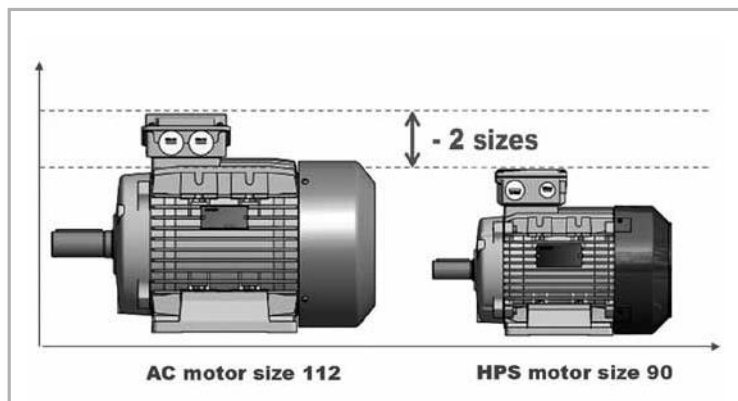

ⓧPending approval by IEC

MERGING TECHNOLOGIES

All these combined features enable engineers to achieve compact efficient motor solutions, particularly for such applications involving pumps, fans and compressors that are substantially more compact, lighter in weight and less expensive to run.

And all these benefits are provided from one development source due to Lafert's in-house technology and the ability to harness the best from proven components such as the AC induction motor's standard stator and the surface-mounted permanent magnet rotor from the brushless servo motor.

The High Performance motor can be used with a standard servo drive when fitted with an appropriate transducer but, ideally, it should be used in conjunction with a sensorless drive to maximise the motors performance and superior efficiencies for the specific application.

Lafert can deliver drives controlling stand-alone PM motors (HPS range) or drives integrated into the PM motors (HPI range).



RANGE OF PRODUCTS

A range of solutions to meet specific demand

- Integral construction (HPI range) or stand-alone drive (HPS range)
- Sensorless control or with speed transducer
- Serial isolated RS485 (eventually for Cascade connection) or serial isolated CANBus

TECHNICAL DESCRIPTION

BRIEF DESCRIPTION

The following features of our HP Motors may vary depending on series and type

- Admissible environmental temperature from -15°C up to $+40^{\circ}\text{C}$, with altitudes 1000 m above sea level
- Mounting IM B3, B5, B14, B34, B35
- Flange concentricity degree $\times N$ balancing vibration $\times N$ dynamic balancing with half key
- Shaft designed according to the standard version with key (also available without key)
- Available speeds 1500, 1800, 3000, 3600, 4500 rpm
- Drive operating voltage 230 or 400 Vac
- Insulation class F temperature rise to class B (TEFC execution)
- IP55 degree of protection for the whole range
- On-Off PTO switch for thermal protection (NTC and PTC are available)
- Optional feedback by choice resolver, encoder, tacho and Hall sensors (several combinations may be added to this list)
- Reduced dimensions
- Rare earth permanent magnets

DEFINITIONS

- Rated torque (M_n) Torque available on the shaft continuously (service S1) with rated speed and with a winding current equivalent to the rated current.
- Peak torque (M_{pk}) Torque available on the shaft discontinuously, with a winding current equivalent to the peak current.
- Rated current (I_n) Current supplied to the motor continuously at a rated speed, required to develop rated torque.
- Peak current (I_{pk}) Current supplied to the motor discontinuously within a wide range of speed, required to develop peak torque (not to be exceeded to avoid magnet demagnetization).
- Voltage constant (K_e) Ratio between voltage induced by the rotor rotation (RMS value for sinusoidal motor, peak value for trapezoidal motor) at a certain number of revolutions and angular speed ($\omega = 2 \times \pi \times n / 60$ where n is the speed expressed in rpm) measured in rad/sec.
- Torque constant (K_t) Ratio between torque on the shaft and the current RMS value for sinusoidal motors, peak value for trapezoidal motors (equivalent to the voltage constant of a trapezoidal motor and to that of a sinusoidal motor multiplied by $\sqrt{3}$).
- Back electromotive force (B.E.M.F) Voltage induced by the rotor rotation (RMS value for sinusoidal motor, peak value for trapezoidal motor) at a certain number of revolutions.



QUALITY SYSTEM CERTIFICATE

The strictness of our quality control assures the flawless operation and reliability of our products. Our quality is confirmed by the Certificate ISO 9001 awarded by CERMET, a certification body authorized by ACCREDIA.

SAFETY STANDARDS

Our motors comply with the requirements of the International Standard IEC 60034 for rotating electrical machines as well as with the following European Directives: Low Voltage Directive (LV) 2006/95/EC, Electromagnetic Compatibility Directive (EMC) 2004/108/EC.

All products comply with the requirements of the Directive Machines (MD) 2006/42/EC. In accordance with this Directive, induction motors are components and intended solely for integration into other machines. Commissioning is forbidden until conformity of the end-product with this Directive is proved.



The CE marking was applied for the first time in 1995.

When operating the motor, the observance of the Regulation EN 60204-1 and safety instructions indicated in our Operating Instructions must be complied with.



Motors complied with many other international standards are available on request. Motors approved by UL Underwriters Laboratories Inc.

The HPS motors comply with the relevant standards and regulations, especially

ELECTRICAL	General stipulations for electrical machines	IEC 60034-1
	Terminal markings and direction of rotation of rotating electrical machines	IEC 60034-8
	Selection of energy-efficient motors including variable speed applications-application guide	IEC/ST 60034-31
	Insulating materials	IEC 60085
MECHANICAL	Dimensions and output ratings	IEC 60072
	Mounting dimensions and relationship frame sizes-output ratings, IM B3, IM B5, IM B14	IEC 60072
	Cylindrical shaft ends for electric motors	IEC 60072
	Degrees of protection	IEC 60034-5
	Methods of cooling	IEC 60034-6
	Mounting arrangements	IEC 60034-7
	Mechanical vibration	IEC 60034-14
	Mounting flanges	DIN 42948
	Tolerances of mounting and shaft extensions	DIN 42955
	Classification of environmental conditions	IEC 60721-2-1
Mechanical vibration&balancing	ISO 8821	

STANDARDS AND REGULATIONS

COMPLIANCE WITH EMC DIRECTIVE

In the great majority of cases, the HPI Drive is used by professionals of the trade as a complex component forming part of a larger appliance, system or installation. It must be noted that the responsibility for the final EMC properties of the appliance, system or installation rests with the installer.

EMC GENERAL STANDARDS

The product standards are stated in EN 61800-3 (IEC 61800-3) and variable speed electrical power drive systems-Part 3. EMC product standard including specific test methods.

The HPI Motors comply with

EN 61800-3, unrestricted distribution¹⁾

EN 61800-3, restricted distribution

Residential, commercial and light industrial environment EN 61000-6-3²⁾, EN 61000-6-1

Industrial environment EN 61000-6-2, EN 61000-6-4

1) Emission levels stated by EN 61800-3 unrestricted distribution are only fulfilled by HPI Motors with class B-1 filter.

2) Emission levels stated by EN 61000-6-3 are only fulfilled by HPI Motors with class B-1 optional filter.

EMC IMMUNITY

If there are problems with low frequency interference (ground loops), screened cable used for bus, standard bus, control cables and signal interface can be left open at one end.

STANDARDS AND REGULATIONS

BASIC STANDARDS

EMISSIONS

EN 55011 Limits and methods of measuring radio disturbance characteristics of industrial, scientific and medical (ISM) radio-frequency equipment

EN 55022 Limits and methods of measuring radio disturbance characteristics of information technology equipment

EN 61000-3-2 Limits for harmonic current emissions (equipment input current ≤ 16 A)

EN 61000-3-12 Limits for harmonic current emissions (equipment input current ≥ 16 A)

EN 61000-6-4 Electromagnetic compatibility (EMC)-Part 6-4, Generic standards-Emission standard for industrial environments

EN 61000-6-3¹⁾ Residential, commercial and light industrial environment

1) Emission levels stated by EN 61000-6-3 are only fulfilled by HPI Motors with class B-1 optional filter.

IMMUNITY

EN 61000-2-4 (IEC 61000-2-4) Compatibility levels Simulation of voltage and frequency fluctuations, harmonics and commutation notches on the power line

EN 61000-4-2 (IEC 61000-4-2) Electrostatic discharge (ESD) Simulation of electrostatic discharge

EN 61000-4-4 (IEC 61000-4-4) Fast transients, burst 5/50 nS Simulation of transients caused by switching of contactors, relays or similar devices

EN 61000-4-5 (IEC 61000-4-5): Surges 1.2/50 μ S. Simulation of transients caused by e.g. lightning that strikes near an installation

EN 61000-4-3 (IEC 61000-4-3) Radio-frequency electromagnetic field. Amplitude modulated. Simulation of interference caused by radio transmission equipment

EN 61000-4-6 (IEC 61000-4-6) RF common mode. Simulation of the effect from radio-transmitting equipment connected to connection cables

ENV 50204 Radio-frequency electromagnetic field. Pulse modulated. Simulation of interference caused by GSM mobile phones. General aspects of EMC emissions for high frequency shielding, screened cables used for CanBus or RS485, standard bus, control cables and signal interface must in general be connected to the enclosure at both ends

EN 61000-6-2 Electromagnetic compatibility (EMC)-Part 6-2 Generic standards-Immunity for industrial environments

EN 61000-6-1 Residential, commercial and light industrial environment

STANDARDS AND REGULATION

VIBRATION AND SHOCK

HPI Motors have been tested according to a procedure based on the following standards:

IEC 60068-2-6 Vibration (sinusoidal) - 1970
IEC 60068-2-34 Random vibration broad-band- general requirements
IEC 60068-2-35 Random vibration broad-band- high reproducibility
IEC 60068-2-36 Random vibration broad-band- medium reproducibility

HPI Motors comply with requirements that correspond to conditions in the standards mentioned above.

AIR HUMIDITY

HPI Motors have been designed to meet the IEC 60068-2-3 standard, EN 50178 item 9.4.2.2/DIN 40040, class E, at 40°C.

Cyclic damp heat according to IEC 60068-2-30, 40°C.

AGGRESSIVE ENVIRONMENTS

In common with all electronic equipment, a HPI drive contains a large number of mechanical and electronic components, all of which are vulnerable to environmental effects to some extent.

Therefore the HPI drive should not be installed in environments with airborne liquids, particles or gases capable of affecting and damaging the electronic components.

Failure to take the necessary protective measures increases the risk of stoppages, thus reducing the life of the drive. Damp and moisture can be carried through the air and condense in the drive. In addition to this, damp and moisture may cause corrosion of components and metal parts.

Steam, oil and salt water may cause corrosion of components and metal parts.

In environments with high temperatures and humidity, corrosive gases such as sulphur, nitrogen and chlorine compounds will cause chemical processes on the drive converter components.

Such chemical reactions will rapidly affect and damage the electronic components.

Mounting HPI drive in aggressive environments will increase the risk of stoppages and furthermore considerably reduce the life of electronic converter.

Before the installation, the ambient air should be checked for damp and moisture, particles and gases. This may be done by observing existing installations in this environment. Typical indicators of harmful airborne damp and moisture are water or oil on metal parts, or corrosion of metal parts.

Excessive dust particle levels are often found on installation cabinets and existing electrical installations.

One indicator of aggressive airborne gases is blackening of copper rails and cable ends on existing installations.

CONDITIONS OF INSTALLATION

ELECTRICAL TOLERANCES

For industrial motors to EN 60034-1, certain tolerances must be allowed on guaranteed values, taking into consideration the necessary tolerances for the manufacture of such motors and the materials used. The standard includes the following remarks:

1- It is not intended that guarantees necessarily have to be given for all or any of the items involved. Quotations including guaranteed values subject to tolerances should say so, and the tolerances should be in accordance with the table.

2- Attention is drawn to the different interpretation of the term guarantee. In some countries a distinction is made between guaranteed values and typical or declared values.

3- Where a tolerance is stated in only one direction, the value is not limited in the other direction.

Values for	Tolerance
Efficiency (η) (by indirect determination)	- 0.15 (1 - η) at $P_N \leq 150$ kW - 0.1 (1 - η) at $P_N > 150$ kW
Power factor ($\cos \varphi$)	$\frac{1 - \cos \varphi}{6}$, minimum 0.02, maximum 0.07
Rated current with rated torque and revolutions (measurement in S1 duty cycle at rated speed with $\vartheta_{amb} \leq 40$ °C and altitude ≤ 1000 m above sea level)	$I_n \pm 5\%$
Back electromotive force E_{bemf}	$E_{bemf} \pm 5\%$
Peak torque (M_k)	- 10% of the guaranteed value (after allowing for this tolerance, M_k/M_N not less than 1.6)
Moment of inertia (J)	$\pm 10\%$ of the guaranteed value

MECHANICAL TOLERANCES

According to IEC 60072-1, the following tolerances on mechanical dimensions of electric motors are permitted:

Parameter	Code	Tolerance
Shaft height	H	- up to 132 -0.5 mm
Diameter of shaft end ¹⁾	D	- from 11 to 28 mm ± 0.05 - from 38 to 48 mm k6
Hub key width	F	h9
Flange spigot	N	- up to 132 ± 0.05 - over size 132 h6

1) Centering holes in shaft extension to DIN 332 part 2

CONDITIONS OF INSTALLATION

THERMAL PROTECTION AND DERATING

The HPI Motors are thermally protected in case limits are exceeded (140°C), another protection is provided through the drive.

DERATING FOR AMBIENT TEMPERATURE

The ambient temperature (T_{amb}) is the maximum temperature allowed. If HPI Motor is operated at temperatures above 40 °C, a derating of the continuous output current is necessary.

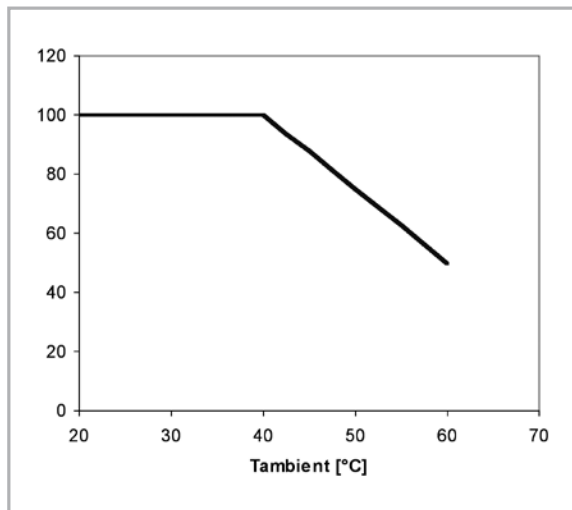

DERATING FOR AIR PRESSURE

Below 1000 m altitude no derating is necessary. Above 1000 m the ambient temperature (T_A) or max. rated output current (I_N) must be derated in accordance with the following diagram.

See the below diagram for derating of output current versus altitude at $T_A \leq \text{max. } 40^\circ\text{C}$

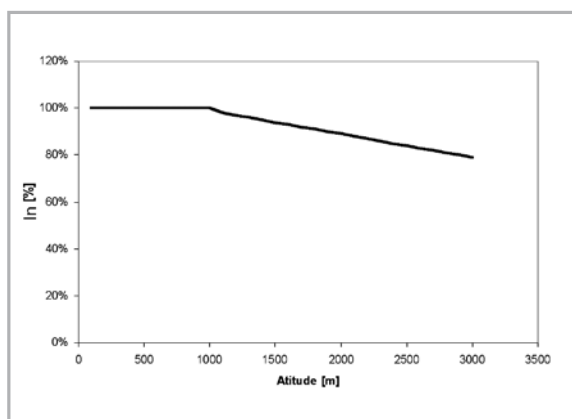

CONDITIONS OF INSTALLATION

DERATING FOR RUNNING AT LOW SPEED

When a centrifugal pump or a fan is controlled by a HPI Motor, it is not necessary to reduce the output at low speed because the load characteristic of the centrifugal pumps/fans, automatically ensures the necessary reduction.

HPI motors running constant load torque applications continuously at low speed must be derated (see diagram) or an independent fan must be used.

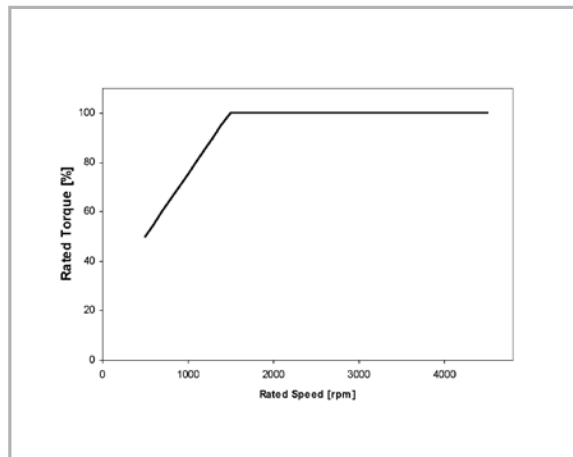

EFFICIENCY

The efficiency varies with the speed and torque. Refer to HPI and HPS efficiency and torque curves.

GALVANIC ISOLATION (PELV)

Galvanic (ensured) isolation is obtained by fulfilling requirements concerning higher isolation and by providing the relevant clearance/clearance distances. These requirements are described in the EN 50178 standard.

In HPI Series all control terminals are supplied from or in connection with extra low voltage (PELV).

The components that make up the electrical isolation, as described below, also comply with the requirements concerning higher isolation and the relevant test as described in EN 50178. The galvanic isolation can be shown in three locations (see drawing below), namely

1. Power supply (SMPS) including signal isolation of VDCbus, indicating the intermediate voltage.
2. Gate drive that runs the IGBTs (opto couplers)
3. DCbus Voltage transducer (opto couplers)
4. Current transducers (Hall Effect-Based Current Sensor).

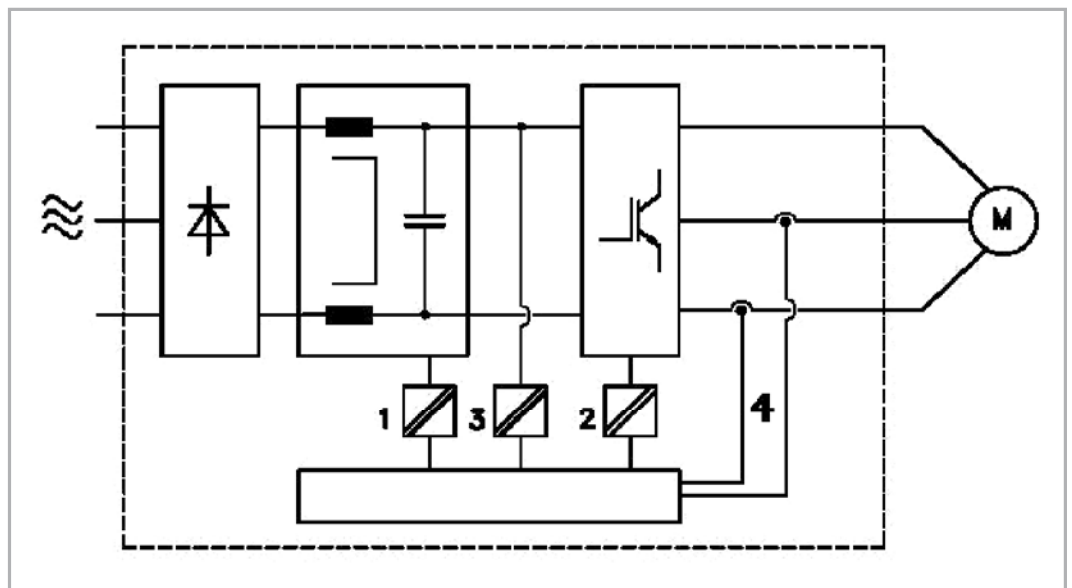

EARTH LEAKAGE CURRENT

Earth leakage current is primarily caused by the capacitance between motor phases and the motor frame. The RFI filter contributes additional leakage current, as the filter circuit is connected to earth through capacitors (C_y).

The size of the leakage current to the ground depends on the following factors, in order of priority

- 1 - Switching PWM frequency
- 2 - Motor grounded on site or not

The leakage current is of importance to safety during handling/operation of the drive if (by mistake) the drive has not been earthed.

OVER VOLTAGE PROTECTION

The voltage in the intermediate circuit is increased when the motor acts as a generator. This occurs in two cases

- 1 - The load generates energy.
- 2 - During deceleration (ramp-down) if the moment of inertia is high, the load is low and the ramp-down time is too short for the energy to be dissipated as a loss in the HPI frequency converter, the motor and the installation.

The drive turns off to protect the IGBT transistors and the intermediate circuit capacitors when a certain voltage level is reached on DCbus.

MAINS SUPPLY INTERFERENCE/HARMONICS

A HPI integral drive takes up a non-sinusoidal current from mains. A non-sinusoidal current can be transformed by means of a Fourier analysis and split up into sine wave currents with different frequencies, i.e. different harmonic currents I_N with 50 Hz as the basic frequency.

Some of the harmonic currents might disturb communication equipment connected to the same transformer or cause resonance in connection with power-factor correction batteries.

To ensure low, harmonic currents, for the residential and commercial environments, an optional harmonic filter is necessary.

MECHANICAL DESIGN

DEGREES OF PROTECTION

Degrees of mechanical protection for machines are designated in accordance with IEC 60034-5 by the letters IP and two characteristic numerals.

First numeral Protection against contact and ingress of foreign bodies

IP	Description
0	No special protection
1	Protection against solid foreign bodies larger than 50 mm (Example: inadvertent contact with the hand)
2	Protection against solid foreign bodies larger than 12 mm (Example: inadvertent contact with the fingers)
3	Protection against solid foreign bodies larger than 2.5 mm (Example: Wires, tools)
4	Protection against solid foreign bodies larger than 1 mm (Example: Wires, bands)
5	Protection against dust (harmful deposits of dust)
6	Complete protection against dust

Second numeral Protection against ingress of water

IP	Description
0	No special protection
1	Protection against vertically falling water drops (condensation)
2	Protection against dropping water when inclined by up to 15°
3	Protection against waterspray at up to 60° from vertical
4	Protection against water splashed from any direction
5	Protection against water projected by a nozzle from any direction
6	Protection against heavy seas or water projected in powerful jets

MECHANICAL DESIGN

BEARING LUBRICATION AND MAINTENANCE

All motors have bearings type 2ZC3 with grease suitable for high and low temperature and permanent lubrication.

Grease type WT (asonic GHY 72) or LHT 23 (multemp) or ens suitable for low and high temperature (-40 to 140 °C)

COOLING

TEFC execution as standard.

Surface cooling, independent of the direction of rotation.

VIBRATION

The amplitude of vibration in electric motors is governed by EN 60034-14 Mechanical vibration of rotating electrical machines with shaft heights 56 and larger - methods of measurement and limits.

Standard motors are designed to vibration grade A (normal). Vibration grade B is available at extra cost.

Rotors are at present dynamically balanced with half key fitted as per DIN ISO 8821. Other balancing only on request.

The motors are identified as follows:

- ☐H☐ or ☐blank☐ means balanced with half key
- ☐F☐ means balanced with full key
- ☐N☐ means no key

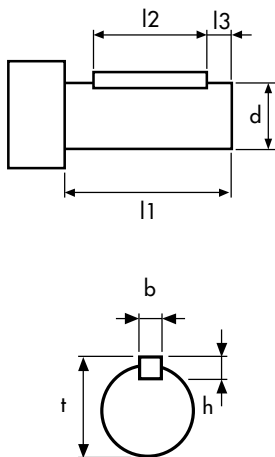

POSITION AND DIMENSIONS OF KEY

Frame size	d x l1	b x h	l2	l3	t
71	14 x 30	5 x 5	20	5	16
90	24 x 50	8 x 7	40	6	27
112	28 x 60	8 x 7	50	6	31
132	38 x 80	10 x 8	70	5	41

Dimensions in mm.

For larger shafts in special design the dimensions l2 and l3 are maintained.

MOTOR NAMEPLATE

NAMEPLATE EXAMPLE - HPS RANGE



NAMEPLATE EXAMPLE - HPI RANGE

