

## THREE-PHASE MOTORS

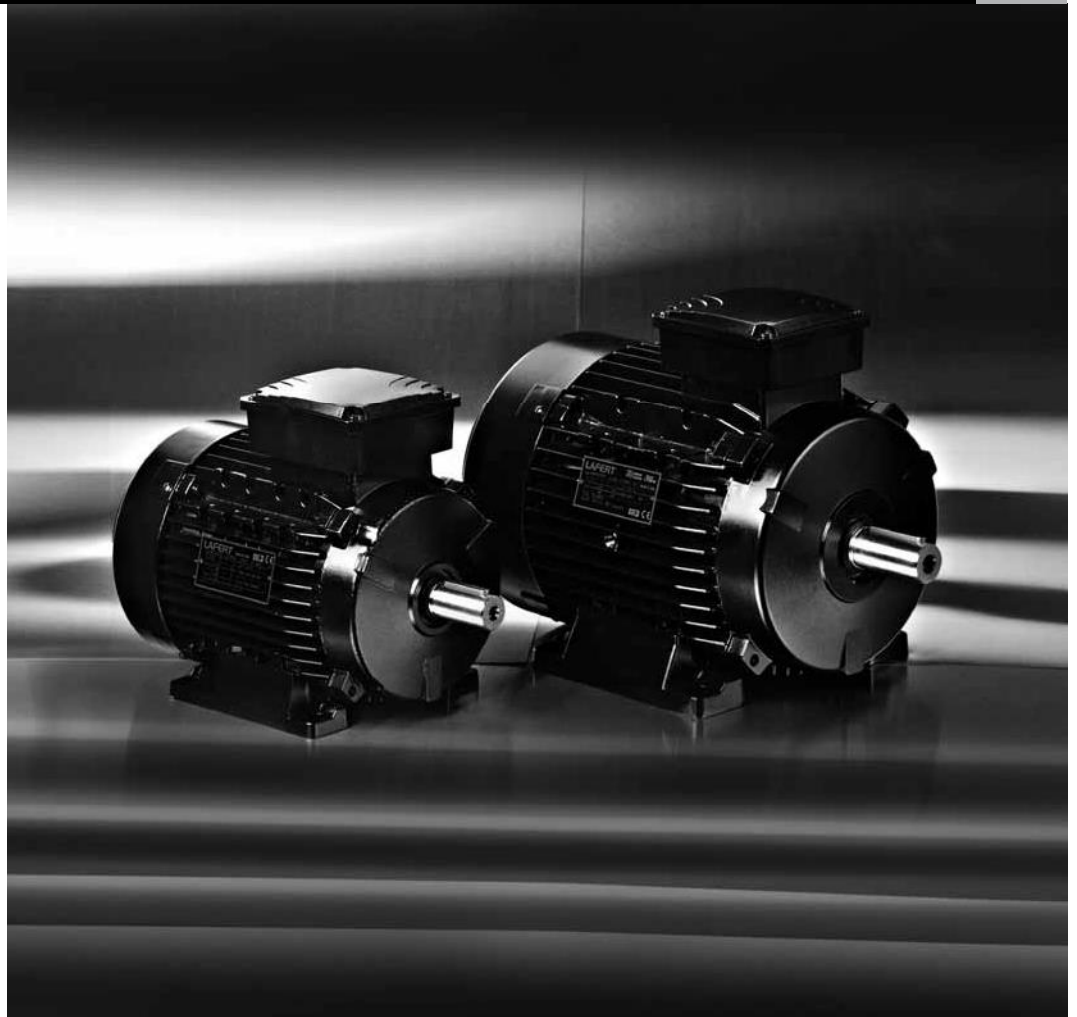

## MECHANICAL DESIGN

### TERMINAL BOX

The location of the terminal box in standard design is on top; on the right or on the left are possible.

Motors 71-160 frame size have removable feet for easy change of terminal box position

For motors with mountings IM B6, IM B7, IM B8, IM V5, IM V6 the location of the terminal box is related to an IM B3 mounting.

The position of the entry openings can be adjusted to suit the existing connection facilities by turning through 90°. Should special accessories be used (temperature detectors, anti-condensation heating, etc.) please enquire.

For motors in standard design, the cable gland does not belong to our scope of delivery.

For plastic terminal boxes, only plastic glands may be used (shock protection).

When using screened leads, a metal terminal box is required.

Direction of cable entries

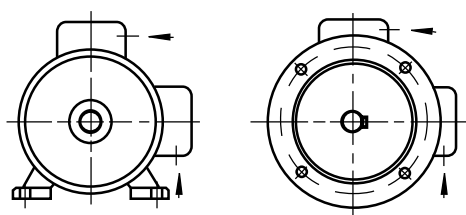

Frame size	Degree of protection	Thread for cable entry		Max. cable section mm <sup>2</sup>	Terminal thread	Max. external cable diam. mm
		Metric <sup>1)</sup>	Pg <sup>2)</sup>			
56 - 71	IP 55	1 x M16/1 x M20	1 x Pg 11/1 x Pg 13.5	2.5	M4	12
80	IP 55	1 x M25/1 x M20	1 x Pg 13.5/1 x Pg 16	2.5	M4	16
90 - 112	IP 55	1 x M25/1 x M20	1 x Pg 13.5/1 x Pg 16	4	M5	16
132	IP 55	2 x M32	2 x Pg 21	4	M5	20
160	IP 55	2 x M40	2 x Pg 29	16	M6	28
180	IP 55	2 x M40/1 x M20		35	M8	28
200	IP 55	2 x M40/1 x M25		35	M8	34
225	IP 55	2 x M50/1 x M25		50	M10	34
250 - 280	IP 55	2 x M50/1 x M25		50	M10	40
315	IP 55	2 x M63/1 x M25 <sup>3)</sup>		185	M12	48

1) Pitch 1.5

2) Pg thread to DIN 40 430 (on request)

3) Terminal box with unscrewable cable entry plate

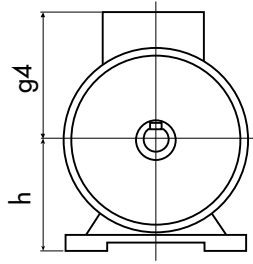

Terminal box on top

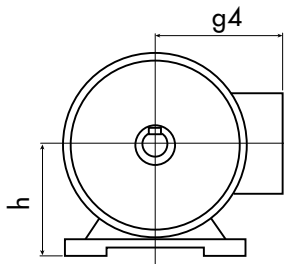

Terminal box at the side

STANDARD DESIGN

Frame size h	g <sub>4</sub>	A	B	Material
56	98	91	93	Plastic UL 94 V0
63	103	91	93	Plastic UL 94 V0
71	112	91	93	Plastic UL 94 V0
80	129	111	116	Plastic UL 94 V0
90	138	111	116	Plastic UL 94 V0
100	145	111	116	Plastic UL 94 V0
112	161	111	116	Plastic UL 94 V0
132	198	133	133	Aluminium
160	238	150	150	Aluminium
180	268	187	162	Cast Iron
200	300	233	186	Cast Iron
225	335	233	186	Cast Iron
250	366	260	218	Cast Iron
280	408	260	218	Cast Iron
315	530	320	280	Cast Iron

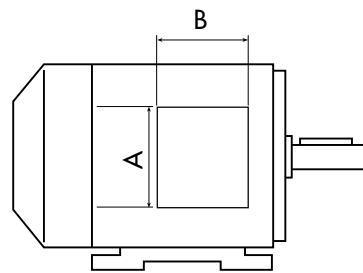

left <sup>1)</sup>

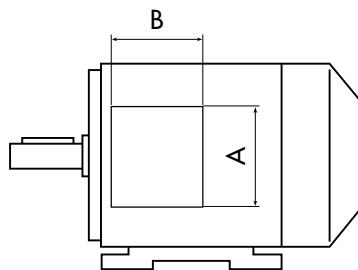

right

SPECIAL DESIGN

Frame size h	g <sub>4</sub>	A	B	Material
56	100	94	94	Aluminium
63	105	94	94	Aluminium
71	114	94	94	Aluminium
80	139	110	110	Aluminium
90	148	110	110	Aluminium
100	155	110	110	Aluminium
112	171	110	110	Aluminium
180	285	209	220	Cast Iron
200	310	241	246	Cast Iron
225	334	272	254	Cast Iron
250	375	272	254	Cast Iron
280	409	272	254	Cast Iron

1) On frame size 56-63 the terminal box is supplied displaced towards the non-drive end

## CONNECTION DIAGRAMS

Windings of standard three-phase single speed motors can be connected either in star or delta connection.

### STAR CONNECTION

A star connection is obtained by connecting W2, U2, V2 terminals to each other and the U1, V1, W1 terminals to the mains. The phase current and voltage are

$$I_{ph} = I_n ; U_{ph} = U_n / \sqrt{3}$$

where  $I_n$  is the line current and  $U_n$  the line voltage referred to the star connection.

### DELTA CONNECTION

A delta connection is obtained by connecting the end of a phase to the beginning of the next phase.

The phase current  $I_{ph}$  and the phase voltage  $U_{ph}$  are

$$I_{ph} = I_n / \sqrt{3} ; U_{ph} = U_n$$

where  $I_n$  and  $U_n$  are referred to the delta connection.

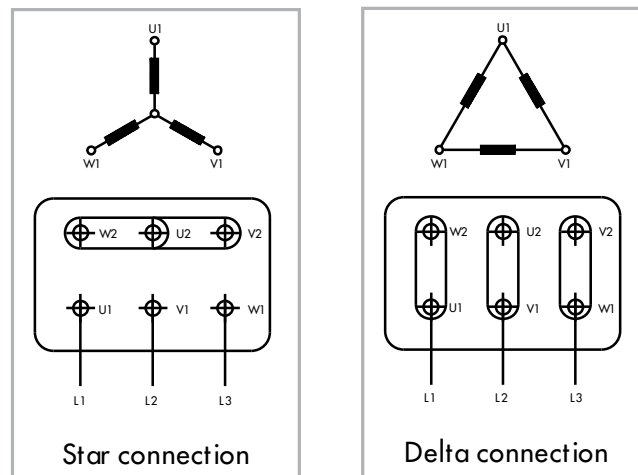

### STAR-DELTA STARTING

Star-delta starting allows a peak current reduction. It can be used only when the reduced starting torque obtained is higher than the resistant torque. Actually, it should be noted that the torque of an induction squirrel-cage motor is directly proportional to the square of the voltage. Motors whose rated voltage with delta connection corresponds to the mains voltage, can be started with the star-delta method.

All motors can be supplied with windings designed for star-delta starting (for example 400 V  $\Delta$  / 690 V Y).

## TWO SPEED MOTORS

Standard pole-changing motors are designed for single voltage and direct-on-line starting.

When the ratio between the two speeds is from 1 to 2, the standard motors have one single winding (Dahlander connection). For the other speeds, the motors have two separate windings.

### AM/AMV - two separate windings

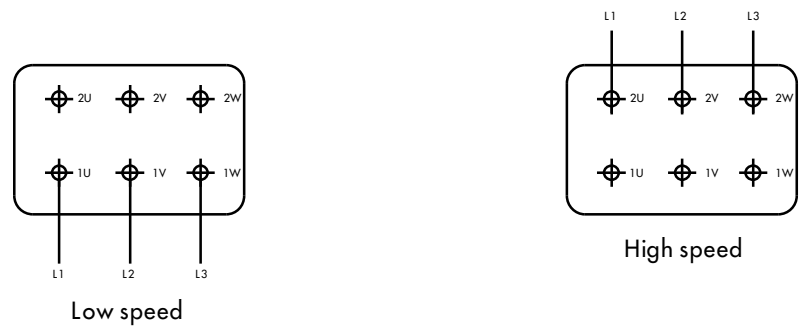

### AM - Dahlander connection $\Delta/YY$

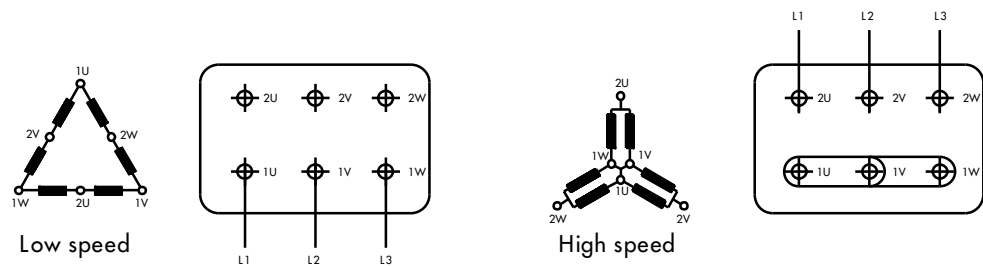

### AMV - Dahlander connection Y/YY

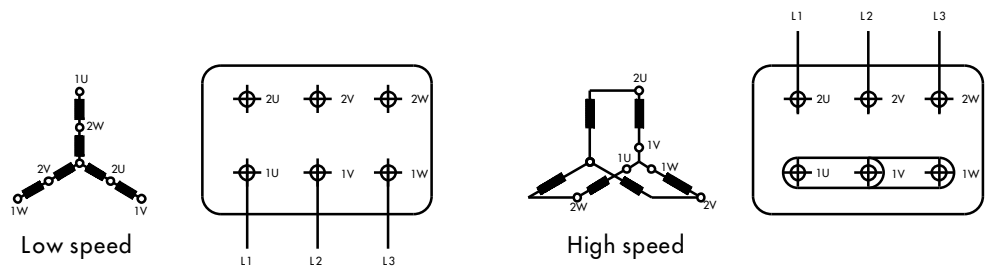

## CAGE MOTORS DRIVEN BY FREQUENCY CONVERTERS

Motors frame sizes 90 upwards in standard design are suitable for operation on static frequency converters, taking into account the following remarks:

- Maximum converter output voltage 500V at peak voltages  $\hat{U} \leq 1460\text{V}$  and  $du/dt \leq 13\text{ kV/us}$ . For higher converter output voltages or stresses, a special insulation is required.
- With square characteristic of the load torque, motors can be driven with their rated torque.
- For constant torque, the rated torque of motors with internal cooling must be reduced due to reduced cooling air inlet. Depending on the control range, the use of an external fan would be advisable.
- The motors frame sizes 90 – 112 are suitable for a maximum output frequency of the converter of 60 Hz (e.g. applications with square torque, control range 1:0, such as pumps and fans). For higher frequencies, a special range with type designation AMI is available on request. From frame size 132 upwards, motors designed  $\Delta/Y$  230/400 V, 50 Hz can be operated in delta with a maximum frequency of 87 Hz (observe mechanical limit speed).

The motors frame size 56 – 80 can be operated on single-phase converters up to maximum 60 Hz. (Special range with type designation AMI for operation on three-phase converters with output voltage  $\geq 400\text{ V}$  and output frequency  $> 60\text{ Hz}$ ).

The electrical values and dimensions of the range AMI in frame size 56 to 112 are identical to AM motors (see data tables pages 50-52).

Note: 75 kW, 2 poles and up - insulated bearing are recommended when inverter fed.

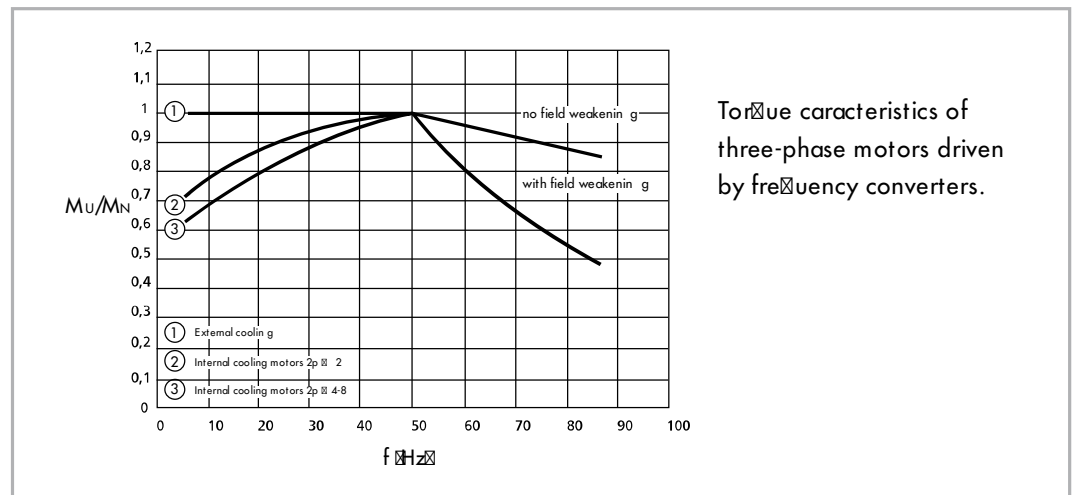

### NOISE

Depending on the operating point and converter type, converter-fed motors produce between approx. 4 - 10 dB(A) higher noise values than when supplied from the mains. For motors driven with a frequency over 50 Hz, more fan noise is produced. We recommend the use of an external fan.

## SPARE PARTS

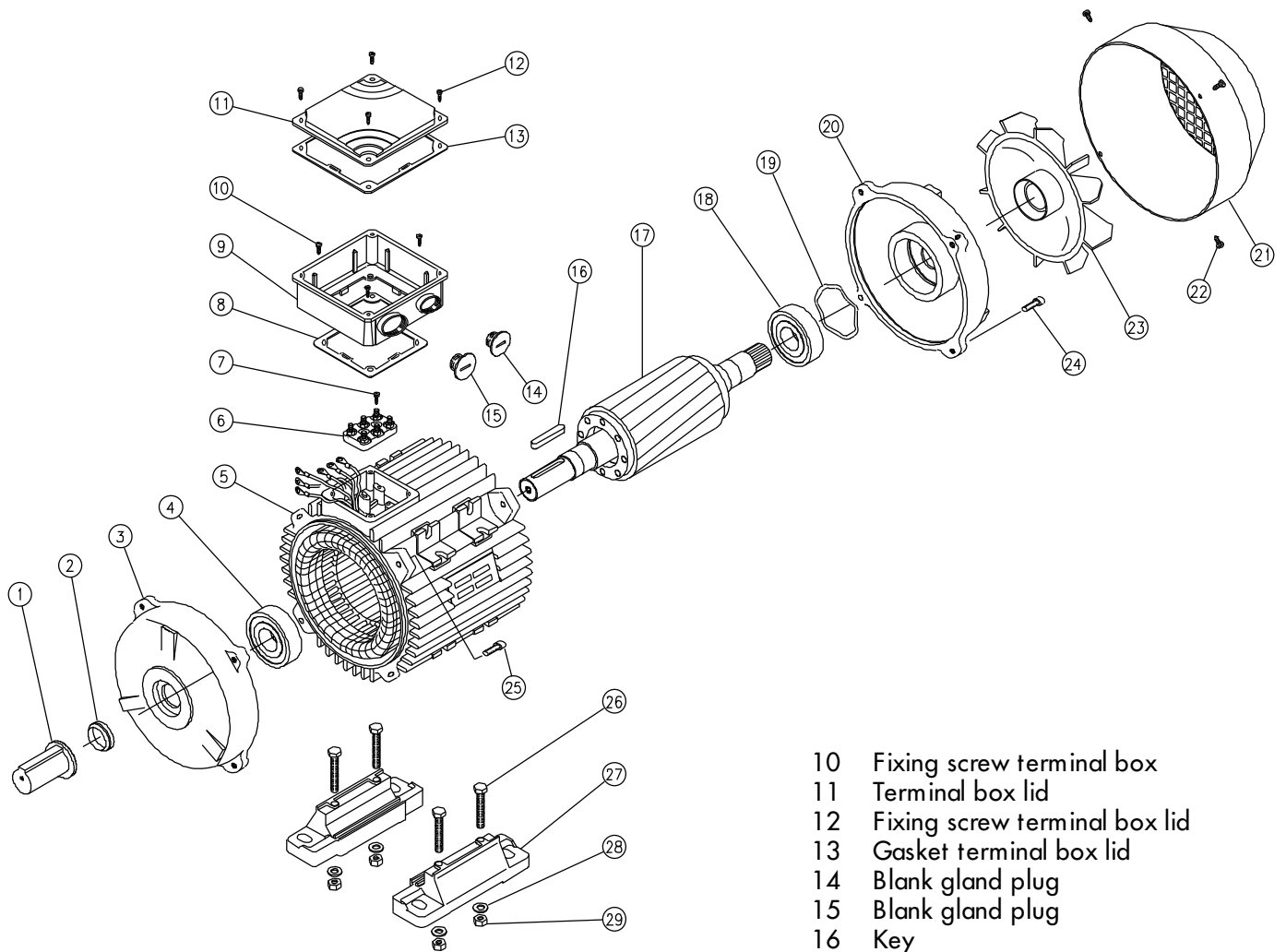

### PART DESCRIPTION

- 1 Shaft protection
- 2 Dust seal drive end
- 3 Endshield drive end
- 4 Bearing drive end
- 5 Stator frame
- 6 Terminal board
- 7 Fixing screw terminal board
- 8 Gasket terminal box
- 9 Terminal box

- 10 Fixing screw terminal box
- 11 Terminal box lid
- 12 Fixing screw terminal box lid
- 13 Gasket terminal box lid
- 14 Blank gland plug
- 15 Blank gland plug
- 16 Key
- 17 Rotor complete
- 18 Bearing non-drive end
- 19 Pre-load washer
- 20 Endshield non-drive end
- 21 Fan cover
- 22 Fixing screw fan cover
- 23 Fan
- 24 Fixing bolt endshield non-drive end
- 25 Fixing bolt endshield drive end
- 26 Fixing bolt motor feet
- 27 Motor feet
- 28 Fixing washer motor feet
- 29 Fixing nut motor feet

Only motors 71-160 frame size have removable feet for easy change of terminal box position

In enquiries and orders for spare parts please state always

Designation of spare part, motor type, mounting arrangement, motor serial number (Product No. when available)

Enquiries and orders cannot be handled without these data.

## TYPE DESIGNATION

Apart from other information, it is necessary to specify the exact type designation in all enquiries, when ordering spare parts or replacement motors or when asking for documentary information.

The type designation of our motors comprises 8 points of reference, each of which may consist of several letters and/or numerals. The meaning of each symbol can be seen from the following table. For motors not included in our standard range, special symbols may be used which are not listed here.

Ref. point	Meaning	Description of symbols used for our motors	
1	Type of motor	A	Asynchronous motor
2	Cooling	M	Surface cooled with external fan, cooling fins
		G	Surface cooled without external fan, cooling fins
		MFV	Surface cooled with forced ventilation, cooling fins
3	Type of motor	blank	Three-phase motor, standard efficiency IE1 code
		EE	Three-phase motor, high efficiency IE2 code
		H	Three-phase motor, efficiency to EPACT regulations
		HE	Three-phase motor, high efficiency IE2 code 50 - 60 Hz
		PE	Three-phase motor, premium efficiency IE3 code
		PH	Three-phase motor, premium efficiency EISA regulations
		V	Three-phase two speed motor for driving fans
		I	Special design for three-phase motor driven with frequency converter
4	Shaft centre height	56, 63, 71, 80, 90, 100, 112, 132, 160, 180, 200, 225, 250, 280, 315	
5	Frame length	Z	Mechanical dimension (short)
		S	
		M	
		L	Mechanical dimension (long)
6	Mechanical design and output value	A	
		B	
		...	
		Z	
7	Frame material	A	Aluminium frame
		G	Cast iron frame
8	Number of poles	2 - 4/2 4 - 8/4 6 - 4/6 8 - 6/8	

### Example

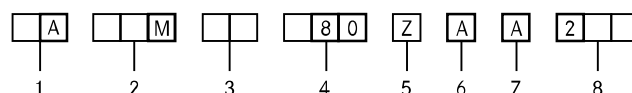



# PREMIUM EFFICIENCY THREE-PHASE MOTORS – IE3

EFFICIENCY LEVEL ACCORDING TO IEC 60034-30:2008  
EFFICIENCY TESTING METHOD IEC 60034-2-1;2007

NOMINAL FULL LOAD EFFICIENCY ACCORDING TO IE3 CODE @ 400 V - 50 HZ

FOR MAINS VOLTAGE  
400 V - 50 HZ



TEMPERATURE RISE TO CLASS B

Type	kW	HP	min <sup>-1</sup>	M <sub>N</sub> Nm	IE3 $\eta$			cos $\varphi$	I <sub>N</sub> 400V	I <sub>A</sub> /I <sub>N</sub>	M <sub>A</sub> /M <sub>N</sub>	M <sub>S</sub> /M <sub>N</sub>	M <sub>K</sub> /M <sub>N</sub>	J		
					50%	75%	100%							10 <sup>-3</sup> kgm <sup>2</sup>	kg	
3000 min <sup>-1</sup> (2 poles)																
AMPE 90S AA	2	1.5	2	2910	4.9	80.1	83.8	85.0	0.72	3.5	9.1	3.9	4.3	4.6	1.6	14
AMPE 90L BA	2	2.2	3	2865	7.3	84.8	85.6	86.0	0.86	4.3	7.9	4.5	4.2	4.7	1.8	16
AMPE 100L AA	2	3	4	2900	9.9	84.6	86.8	87.1	0.85	5.8	10.9	5.5	3.5	4.5	4	22.8
AMPE 112M AA	2	3.7	5	2950	12.0	86.3	88.9	89.9	0.83	7.1	12.8	5.2	2.3	3.8	8.6	33.6
AMPE 112M BA	2	4	5.5	2945	13.0	86.9	88.4	90.1	0.85	7.5	12.6	4.7	2.3	3.8	8.6	33.6
AMPE 112M CA	2	5.5	7.5	2935	17.9	85.6	88.3	89.2	0.78	11.3	11.7	4.7	2.7	4	8.6	33.6
AMPE 132S ZA	2	5.5	7.5	2920	18.0	88.2	89.7	89.8	0.88	10.0	7.7	3.2	2.9	3.6	20.5	53
AMPE 132S TA	2	7.5	10	2930	24.4	89.4	91.0	91.1	0.88	13.5	7.7	3.6	3.3	4.2	22.8	56
AMPE 132M TA	2	9.2	12.4	2935	29.9	89.4	91.0	91.2	0.85	17.0	9.7	4.2	3.9	5.1	25	59
AMPE 132M RA	2	11	15	2935	35.8	89.2	90.8	91.2	0.81	21.4	9.5	4.2	3.7	4.9	25	59
AMPE 160M YA	2	11	15	2935	35.8	88.7	90.5	91.2	0.89	19.5	11.1	3.7	2.7	4.7	51.7	87.8
AMPE 160M ZA	2	15	20	2945	48.6	89.5	91.4	92.0	0.88	26.7	12.5	4.6	3.3	5.9	64	104
AMPE 160L ZA	2	18.5	25	2945	60.0	89.7	91.7	92.4	0.82	35.3	12.8	4.9	3.5	6.3	64	104
AMPE 160L TA	2	22	30	2930	71.7	91.6	92.6	92.7	0.85	40.2	10.9	4.1	3.0	5.3	64	104

For dimensions AMPE 2 poles motors, please see dimensions AMHE motors

Type	kW	HP	min <sup>-1</sup>	M <sub>N</sub> Nm	IE3 $\eta$			cos $\varphi$	I <sub>N</sub> 400V	I <sub>A</sub> /I <sub>N</sub>	M <sub>A</sub> /M <sub>N</sub>	M <sub>S</sub> /M <sub>N</sub>	M <sub>K</sub> /M <sub>N</sub>	J		
					50%	75%	100%							10 <sup>-3</sup> kgm <sup>2</sup>	kg	
1500 min <sup>-1</sup> (4 poles)																
AMPE 90S AA	4	1.1	1.5	1445	7.3	82.3	85.2	85.8	0.70	2.6	8.5	4.6	4.5	4.9	3.7	16.4
AMPE 90L BA	4	1.5	2	1420	10.1	84.7	85.4	85.7	0.76	3.3	7.8	4.1	4.0	4.3	3.7	16.4
AMPE 90L CA	4	1.8	2.4	1420	12.1	83.8	84.9	85.3	0.70	4.3	8.0	4.1	4.0	4.3	3.7	16.4
AMPE 112M AA	4	3.7	5	1450	24.4	87.7	88.6	88.8	0.80	7.5	9.9	3.3	2.7	4.9	16.4	36
AMPE 112M BA	4	4	5.5	1445	26.4	87.9	88.5	88.8	0.82	7.9	9.3	3.1	2.4	4.6	16.4	36
AMPE 132S ZA	4	5.5	7.5	1450	36.2	90.6	91.0	91.2	0.82	10.6	9.4	3.7	3.2	4.3	36	65
AMPE 132M ZA	4	7.5	10	1465	48.9	89.8	91.2	91.5	0.68	17.5	9.7	4.4	3.7	5.1	45	79
AMPE 132M TA	4	9.2	12.4	1455	60.4	90.6	91.2	91.3	0.74	19.7	9.8	4.9	4.2	5.8	57	98
AMPE 160M ZA	4	11	15	1470	71.5	92.2	92.6	92.9	0.79	21.6	10.1	4.6	3.3	4.9	120.7	114
AMPE 160L ZA	4	15	20	1465	97.8	92.1	92.5	92.8	0.78	29.9	10.1	4.4	3.2	4.7	135	120

For dimensions AMPE 4 poles motors, please consult us

## PREMIUM EFFICIENCY THREE-PHASE MOTORS – IE3

EFFICIENCY LEVEL ACCORDING TO EISA  
EFFICIENCY TESTING METHOD CSA C390-10  
VERIFIED BY UL ENVIRONMENT

EFFICIENCY LEVEL ACCORDING TO IEC 60034-30:2008  
EFFICIENCY TESTING METHOD IEC 60034-2-1:2007

NOMINAL FULL LOAD EFFICIENCY ACCORDING TO NEMA MG 1 - TABLE 12-12 (PREMIUM EFFICIENCY)

FOR MAINS VOLTAGE  
460 V - 60 HZ



TEMPERATURE RISE TO CLASS B

Type	kW	HP	min <sup>-1</sup>	M <sub>N</sub> Nm	IE3 $\eta$			cos $\varphi$	I <sub>N</sub> 460V	I <sub>A</sub> /I <sub>N</sub>	M <sub>A</sub> /M <sub>N</sub>	M <sub>S</sub> /M <sub>N</sub>	M <sub>K</sub> /M <sub>N</sub>	J 10 <sup>-3</sup> kgm <sup>2</sup>	kg	
					50%	75%	100%									
3600 min <sup>-1</sup> (2 poles)																
AMPH 90S AA	2	1.5	2	3515	4.1	81.2	84.7	85.5	0.78	2.8	10.0	3.7	3.6	4.3	1.6	14.0
AMPH 90L BA	2	2.2	3	3480	6.0	83.6	86.1	86.5	0.84	3.8	8.5	4.4	4	4.4	1.8	16.0
AMPH 100L AA	2	3	4	3515	8.2	85.8	88.1	88.5	0.86	4.9	10.5	5.6	5.3	5.3	4.0	22.8
AMPH 112M AA	2	3.7	5	3550	10.0	84.0	87.6	88.5	0.86	6.1	16.7	5.1	1.9	5.2	8.6	33.6
AMPH 112M BA	2	4	5.5	3540	10.8	85.3	88.0	88.5	0.87	6.5	15.7	4.7	1.7	4.8	8.6	33.6
AMPH 112M CA	2	5.5	7.5	3530	14.9	86.2	89.0	89.5	0.86	8.9	14.4	4.5	2.5	4.3	8.6	33.6
AMPH 132S ZA	2	5.5	7.5	3540	14.8	87.3	89.6	89.5	0.88	8.8	10.2	3.0	2.6	3.3	20.5	53.0
AMPH 132S TA	2	7.5	10	3540	20.2	88.0	90.3	90.2	0.87	12.0	12.0	3.4	2.9	3.9	22.8	56.0
AMPH 132M TA	2	9.2	12.4	3545	24.8	87.7	90.1	90.2	0.88	14.5	10.0	4.0	3.5	4.7	25.0	59.0
AMPH 132M RA	2	11	15	3535	29.7	87.5	90.4	91.0	0.86	17.7	10.7	4.0	3.5	4.7	25.0	59.0
AMPH 160M YA	2	11	15	3550	29.6	86.6	90.0	91.0	0.89	17.0	10.8	3.5	2.5	4.5	51.7	87.8
AMPH 160M ZA	2	15	20	3555	40.3	90.1	92.0	91.0	0.85	24.4	12.2	4.4	3.1	5.6	64.0	104
AMPH 160L ZA	2	18.5	25	3555	49.7	90.0	92.2	91.7	0.82	31.0	12.5	4.6	3.3	6.0	64.0	104
AMPH 160L TA	2	22	30	3540	59.3	90.7	92.5	91.7	0.84	35.8	10.6	3.9	2.8	5.0	64.0	104

For dimensions AMPH 2 poles motors, please see dimensions AMH motors

Type	kW	HP	min <sup>-1</sup>	M <sub>N</sub> Nm	IE3 $\eta$			cos $\varphi$	I <sub>N</sub> 460V	I <sub>A</sub> /I <sub>N</sub>	M <sub>A</sub> /M <sub>N</sub>	M <sub>S</sub> /M <sub>N</sub>	M <sub>K</sub> /M <sub>N</sub>	J 10 <sup>-3</sup> kgm <sup>2</sup>	kg	
					50%	75%	100%									
1800 min <sup>-1</sup> (4 poles)																
AMPH 90S AA	4	1.1	1.5	1745	6.0	82.8	85.6	86.5	0.7	2.2	8.2	4.4	4.3	4.6	3.7	16.4
AMPH 90L BA	4	1.5	2	1735	8.3	83.5	86.2	86.5	0.7	2.9	7.5	3.8	3.7	4.0	3.7	16.4
AMPH 90L CA	4	1.8	2.4	1730	9.9	85.2	86.7	86.5	0.7	3.8	7.8	3.9	3.8	4.1	3.7	16.4
AMPH 112M AA	4	3.7	5	1765	20.0	87.3	89.3	89.5	0.8	6.5	9.6	3.1	2.5	4.6	16.4	36.0
AMPH 112M BA	4	4	5.5	1760	21.7	87.7	89.4	89.5	0.8	6.9	9	2.9	2.3	4.3	16.4	36.0
AMPH 132S ZA	4	5.5	7.5	1760	29.8	91.0	92.1	91.7	0.8	9.3	9.1	3.5	3	4.1	36.0	65.0
AMPH 132M ZA	4	7.5	10	1760	40.7	90.8	91.5	91.7	0.8	13	9.4	4.1	3.5	4.8	45.0	79.0
AMPH 132M TA	4	9.2	12.4	1760	49.9	90.9	91.6	91.7	0.7	17.2	9.5	4.7	4	5.5	57.0	98.0
AMPH 160M ZA	4	11	15	1770	59.3	91.5	92.5	92.4	0.8	18.7	9.8	4.4	3.1	4.6	120.7	114
AMPH 160L ZA	4	15	20	1765	81.2	92.4	93.0	93.0	0.8	26.3	9.8	4.2	3	4.4	135.0	120

For dimensions AMPH 4 poles motors, please consult us

# HIGH EFFICIENCY THREE-PHASE MOTORS – IE2

EFFICIENCY LEVEL ACCORDING TO IEC 60034-30:2008  
EFFICIENCY TESTING METHOD IEC 60034-2-1;2007

NOMINAL FULL LOAD EFFICIENCY ACCORDING TO IE2 CODE @ 400 V - 50 HZ; IE2 CODE @ 460 V - 60 HZ  
AND NEMA MG 1 - TABLE 12-11 (EPACT) @ 460 V - 60 HZ

Performance data referred @ 400 V - 50 Hz. For performance data @ 460 V - 60 Hz, please consult us.

FOR MAINS VOLTAGE  
400 V - 50 HZ  
460 V - 60 HZ



TEMPERATURE RISE TO CLASS B

Type	kW	HP	min <sup>-1</sup>	M <sub>N</sub> Nm	IE2 $\eta$			cos $\varphi$	I <sub>N</sub> 400V	I <sub>A</sub> /I <sub>N</sub>	M <sub>A</sub> /M <sub>N</sub>	M <sub>S</sub> /M <sub>N</sub>	M <sub>K</sub> /M <sub>N</sub>	J 10 <sup>-3</sup> kgm <sup>2</sup>	kg	
					50%	75%	100%									
3000 min <sup>-1</sup> (2 poles)																
AMHE 71Z AA	2*	0.75	1	2865	2.5	75.0	78.1	79.4	0.71	1.9	5.2	3.1	3.0	3.1	0.69	8.2
AMHE 80Z AA	2	0.75	1	2900	2.5	77.3	78.5	80.5	0.78	1.7	8.4	3.6	3.4	3.6	0.7	9.5
AMHE 80Z BA	2	1.1	1.5	2880	3.6	79.5	81.2	81.5	0.78	2.5	9.5	3.6	3.4	3.6	0.89	11.1
AMHE 80Z CA	2*	1.5	2	2880	5.0	80.5	82.1	82.4	0.78	3.4	7.8	3.5	3.4	3.6	1.1	13.5
AMHE 90S AA	2	1.5	2	2880	5.0	81.0	82.8	82.8	0.80	3.2	10.1	3.6	3.1	4.0	1.56	14.0
AMHE 90L CA	2	2.2	3	2860	7.3	82.5	84.0	84.0	0.85	4.4	10.1	3.5	3.2	3.7	1.8	16.0
AMHE 90L DA	2*	3	4	2880	9.9	85.0	86.0	85.6	0.82	6.1	9.9	3.5	3.3	3.8	2.0	18.0
AMHE 100L AA	2	3	4	2920	9.8	84.1	85.8	85.5	0.84	5.9	10.3	3.5	3.0	4.0	4.05	22.8
AMHE 100L BA	2*	4	5.5	2920	13.1	85.2	86.4	86.1	0.86	7.8	10.4	3.3	3.0	3.8	4.1	22.8
AMHE 112M AA	2	4	5.5	2940	13.0	85.5	87.0	86.8	0.88	7.6	10.7	2.9	2.1	3.3	6.48	27.4
AMHE 112M BA	2*	5.5	7.5	2920	18.0	85.8	87.4	87.3	0.88	10.4	9.9	3.0	2.1	3.2	8.58	34.0
AMHE 112M CA	2*	7.5	10	2900	24.7	86.5	88.3	88.3	0.87	14.2	9.1	3.0	2.2	3.4	10.50	36.0
AMHE 132S YA	2	5.5	7.5	2900	18.1	86.0	88.0	87.9	0.89	10.2	8.6	2.7	2.3	3.2	14.0	46.0
AMHE 132S ZA	2	7.5	10	2900	24.7	86.3	88.6	88.4	0.89	13.8	8.9	2.8	2.5	3.3	16.0	53.0
AMHE 132M ZA	2	9.2	12.5	2920	30.1	88.4	89.9	90.0	0.87	16.9	9.4	3.2	3	3.8	17.5	58.0
AMHE 132M RA	2*	11	15	2920	36.0	88.1	90.0	89.7	0.90	19.8	9.7	3.8	2.6	4.0	17.5	58.0
AMHE 132M TA	2*	15	20	2920	49.1	88.9	90.6	90.3	0.89	27.0	9.7	3.8	2.2	4.0	21.0	75.0
AMHE 160M YA	2	11	15	2930	35.9	88.9	90.2	90.0	0.87	20.4	9.3	2.4	2.2	3.1	51.75	77.0
AMHE 160M ZA	2	15	20	2930	48.9	90.0	91.0	90.8	0.88	27.2	9.6	2.5	2.3	3.1	55.4	87.1
AMHE 160L ZA	2	18.5	25	2935	60.2	90.3	91.6	91.2	0.88	33.3	9.6	2.8	2.4	3.4	59.7	97.5
AMHE 160L TA	2*	22	30	2935	71.6	91.0	91.7	91.5	0.89	38.6	9.9	3.0	2.6	3.7	64.0	108.7
AMHE 180M ZG	2	22	30	2930	71.7	90.9	91.8	91.4	0.89	39.04	7.5	2.3	2.0	2.8	98	163
AMHE 200L PG	2	30	40	2930	97.8	91.3	92.3	92.4	0.88	53.3	6.7	2.4	2.0	2.7	178	228
AMHE 200L RG	2	37	50	2930	120.6	91.6	92.9	92.8	0.90	64.0	6.3	2.3	2.0	2.7	204	242
AMHE 225M PG	2	45	60	2940	146.2	92.8	93.3	93.2	0.89	78.3	6.9	2.3	2.0	2.8	285	308
AMHE 250M PG	2	55	75	2950	178.0	92.9	93.8	93.7	0.90	94.1	8.0	2.3	1.9	2.7	411	405
AMHE 280S G	2	75	100	2960	242.0	93.2	94.5	94.1	0.90	127.8	8.0	2.2	1.9	2.7	791	542
AMHE 280M G	2	90	125	2960	290.4	93.6	94.3	94.4	0.91	151.2	7.7	2.2	1.9	2.6	907	596
AMHE 315S G	2	110	150	2970	353.7	93.7	94.6	94.8	0.90	186.0	7.7	2.0	1.8	2.3	1702	922
AMHE 315M G	2	132	180	2970	424.4	93.6	94.9	95.3	0.90	222.1	7.6	2.0	1.8	2.3	1908	1010
AMHE 315M RG	2	160	220	2970	514.5	94.1	95.2	95.3	0.91	266.3	7.8	2.0	1.8	2.3	2117	1085
AMHE 315L G	2	200	270	2975	642.0	94.1	95.3	95.4	0.90	336.2	7.9	2.0	1.8	2.3	2438	1220

\* Higher output (progressive motor)

# HIGH EFFICIENCY THREE-PHASE MOTORS – IE2

EFFICIENCY LEVEL ACCORDING TO IEC 60034-30:2008  
EFFICIENCY TESTING METHOD IEC 60034-2-1;2007

NOMINAL FULL LOAD EFFICIENCY ACCORDING TO IE2 CODE @ 400 V - 50 HZ; IE2 CODE @ 460 V - 60 HZ  
AND NEMA MG 1 - TABLE 12-11 (EPACT) @ 460 V - 60 HZ

Performance data referred @ 400 V - 50 Hz. For performance data @ 460 V - 60 Hz, please consult us.

FOR MAINS VOLTAGE  
400 V - 50 HZ  
460 V - 60 HZ

## IE2

TEMPERATURE RISE TO CLASS B

Type	kW	HP	min <sup>-1</sup>	M <sub>N</sub> Nm	IE2 $\eta$			cos $\varphi$	I <sub>N</sub> 400V	I <sub>A</sub> /I <sub>N</sub>	M <sub>A</sub> /M <sub>N</sub>	M <sub>S</sub> /M <sub>N</sub>	M <sub>K</sub> /M <sub>N</sub>	J 10 <sup>-3</sup> kgm <sup>2</sup>	kg	
					50%	75%	100%									
1500 min <sup>-1</sup> (4 poles)																
AMHE 80Z AA	4	0.75	1	1430	5.0	79.2	80.3	80.2	0.76	1.8	5.5	2.8	2.7	3.0	2.5	11.0
AMHE 90S AA	4	1.1	1.5	1430	7.3	81.4	82.7	82.5	0.77	2.5	6.1	4.0	3.9	4.1	3.73	18.0
AMHE 90L BA	4	1.5	2	1430	10.0	81.0	83.5	83.0	0.77	3.4	7.9	3.9	3.8	4.0	3.73	19.0
AMHE 100L AA	4	2.2	3	1450	14.5	84.0	85.3	85.1	0.74	5.1	6.0	3.2	3	3.4	5.58	22.4
AMHE 100L BA	4	3	4	1440	19.9	82.6	84.7	86.4	0.77	6.5	8.5	3.4	3.1	3.6	7.3	26.5
AMHE 112M AA	4	4	5.5	1450	26.3	86.0	87.3	87.1	0.78	8.5	6.1	3.1	2.8	3.3	13.3	30.4
AMHE 132S RA	4	5.5	7.5	1450	36.2	87.5	88.3	88.1	0.78	11.4	7.4	3.3	2.7	3.6	30.0	55.0
AMHE 132M TA	4	7.5	10	1450	49.4	88.5	89.4	89.2	0.74	16.4	7.4	3.0	2.4	3.3	36.0	65.0
AMHE 160M ZA	4	11	15	1460	71.9	89.4	90.3	90.1	0.82	22.0	7.9	2.3	2.1	2.9	105.0	108.0
AMHE 160L ZA	4	15	20	1460	98.1	90.6	91.2	91.0	0.84	29.0	7.4	2.5	2.2	3.1	120.7	114.0
AMHE 180M ZG	4	18.5	25	1455	121.4	90.9	91.6	91.4	0.85	34.4	7.8	2.4	2.1	3.0	156	160
AMHE 180L ZG	4	22	30	1460	143.9	91.1	92.0	91.6	0.84	41.3	7.5	2.3	2.0	3.0	175	175
AMHE 200L RG	4	30	40	1460	196.2	90.2	92.8	92.5	0.88	53.2	7.9	2.4	2.0	2.7	281	238
AMHE 225S PG	4	37	50	1470	240.4	92.3	92.9	92.8	0.83	69.3	6.7	2.4	2.0	2.7	487	305
AMHE 225M PG	4	45	60	1480	290.4	92.5	93.2	93.3	0.83	83.9	7.0	2.3	2.0	2.8	575	310
AMHE 250M PG	4	55	75	1480	354.9	93.1	94.0	93.8	0.87	97.3	7.4	2.4	1.9	2.7	728	412
AMHE 280S G	4	75	100	1480	483.9	93.2	94.5	94.4	0.90	127.4	7.5	2.2	1.9	2.6	1741	560
AMHE 280M G	4	90	125	1480	580.7	93.4	94.8	94.7	0.90	152.4	7.7	2.2	1.9	2.6	2037	665
AMHE 315S G	4	110	150	1480	709.8	93.9	95.0	94.9	0.89	188.0	7.8	2.0	1.8	2.3	4026	910
AMHE 315M G	4	132	180	1480	851.8	94.0	95.2	95.1	0.90	222.6	7.8	2.0	1.8	2.3	4387	1120
AMHE 315M RG	4	160	220	1480	1032.4	94.2	95.3	95.3	0.90	269.3	7.9	2.0	1.8	2.3	4968	1185
AMHE 315LG	4	200	270	1480	1290.5	94.3	95.4	95.4	0.90	336.2	7.7	2.0	1.8	2.3	6488	1340

# HIGH EFFICIENCY THREE-PHASE MOTORS – IE2

EFFICIENCY LEVEL ACCORDING TO IEC 60034-30:2008  
EFFICIENCY TESTING METHOD IEC 60034-2-1;2007

FOR MAINS VOLTAGE  
400 V - 50 HZ

TEMPERATURE RISE TO CLASS B

Type	kW	HP	min <sup>-1</sup>	M <sub>N</sub> Nm	IE2 $\eta$			cos $\varphi$	I <sub>N</sub> 400V	I <sub>A</sub> /I <sub>N</sub>	M <sub>x</sub> /M <sub>N</sub>	M <sub>s</sub> /M <sub>N</sub>	M <sub>r</sub> /M <sub>N</sub>	J		
					50%	75%	100%							10 <sup>-3</sup> kgm <sup>2</sup>	kg	
1000 min <sup>-1</sup> (6 poles)																
AMEE 90S AA	6	0.75	1	925	7.7	75.3	75.8	76.2	0.65	2.2	4.6	1.7	1.6	1.8	4.78	15.0
AMEE 90L BA	6	1.1	1.5	935	11.2	78.5	78.7	78.9	0.67	3.0	4.2	1.8	1.8	2.3	6.45	20.3
AMEE 100L AA	6	1.1	1.5	950	11.1	75.7	77.6	79.5	0.67	3.0	5.5	1.9	1.9	2.4	7.48	19.4
AMEE 100L BA	6	1.5	2	950	15.1	78.5	79.4	79.8	0.69	3.9	5.5	2.1	1.5	2.2	11.6	27.1
AMEE 112M AA	6	2.2	3	960	21.9	79.4	81.0	81.8	0.73	5.3	6.1	3.1	2.2	3.1	18.7	39.0
AMEE 132S YA	6	3	4	960	29.8	82.3	82.9	83.5	0.58	8.9	5.6	2.2	1.4	3.2	37.7	55.8
AMEE 132M YA	6	4	5.5	955	40.0	84.1	84.8	85.2	0.66	10.3	5.8	2.1	1.2	2.9	44.4	65.5
AMEE 132M TA	6	5.5	7.5	970	54.1	85.0	86.2	86.5	0.75	12.2	7.0	1.9	1.1	2.7	54.1	64.1
AMEE 160M YA	6	5.5	7.5	975	53.9	84.7	85.6	86.1	0.78	11.7	7.4	2.3	2.3	3.0	75.2	70.5
AMEE 160M ZA	6	7.5	10	970	73.8	85.8	87.3	87.5	0.78	15.8	7.7	3.0	2.8	3.8	103	96.6
AMEE 160L ZA	6	9.2	12.4	965	91.0	86.3	87.4	88.2	0.83	18.1	8.3	3.1	2.7	3.5	125	103
AMEE 160L TA	6	11	15	965	108.9	87.9	88.2	88.7	0.79	22.5	8.0	2.7	2.4	3.2	156	129

NOMINAL FULL LOAD EFFICIENCY ACCORDING TO IE2 CODE @ 400 V - 50 HZ; IE2 CODE @ 460 V - 60 HZ  
AND NEMA MG 1 - TABLE 12-11 (EPACT) @ 460 V - 60 HZ

FOR MAINS VOLTAGE  
400 V - 50 HZ  
460 V - 60 HZ

Performance data referred @ 400 V - 50 Hz. For performance data @ 460 V - 60 Hz, please consult us.

TEMPERATURE RISE TO CLASS B

Type	kW	HP	min <sup>-1</sup>	M <sub>N</sub> Nm	IE2 $\eta$			cos $\varphi$	I <sub>N</sub> 400V	I <sub>A</sub> /I <sub>N</sub>	M <sub>x</sub> /M <sub>N</sub>	M <sub>s</sub> /M <sub>N</sub>	M <sub>r</sub> /M <sub>N</sub>	J		
					50%	75%	100%							10 <sup>-3</sup> kgm <sup>2</sup>	kg	
1000 min <sup>-1</sup> (6 poles)																
AMHE 180LZG	6	15	20	965	148.45	88.5	90.3	90.1	0.83	29.0	7.0	2.3	2.1	2.9	285	172
AMHE 200LPG	6	18.5	25	965	183.09	88.9	90.8	90.6	0.84	35.1	7.0	2.4	2.1	3.2	405	225
AMHE 200LRG	6	22	30	970	216.6	89.3	91.4	91.2	0.85	41.0	7.0	2.3	1.9	3.1	471	275
AMHE 225MPG	6	30	40	975	293.85	89.6	91.7	91.9	0.86	54.8	7.0	2.2	1.9	2.7	801	312
AMHE 250MPG	6	37	50	975	362.41	90.7	92.4	92.5	0.84	68.7	7.0	2.3	2.1	2.7	992	386
AMHE 280SG	6	45	60	980	438.52	91.6	92.9	92.9	0.85	82.3	7.0	2.3	2.0	2.8	1785	560
AMHE 280MG	6	55	75	980	536.0	92.1	93.4	93.3	0.86	98.9	7.0	2.2	1.9	2.7	2208	593
AMHE 315SG	6	75	100	985	727.16	93.1	93.8	93.8	0.87	132.7	7.0	2.1	1.9	2.5	4632	741
AMHE 315MG	6	90	125	985	872.59	93.3	94.1	94.2	0.88	156.7	7.0	2.0	1.8	2.3	5525	920
AMHE 315MRG	6	110	150	980	1071.94	93.2	94.5	94.6	0.89	188.6	6.7	2.0	1.8	2.3	6896	1243
AMHE 315LG	6	132	160	980	1286.33	93.7	94.7	94.8	0.88	228.4	6.7	2.0	1.8	2.3	8023	1428

# HIGH EFFICIENCY THREE-PHASE MOTORS – IE2

EFFICIENCY LEVEL ACCORDING TO EPACT  
EFFICIENCY TESTING METHOD CSA C390  
VERIFIED BY UL UNDERWRITERS LABORATORIES INC.

NOMINAL FULL LOAD EFFICIENCY ACCORDING TO NEMA MG 1 - TABLE 12-11 (EPACT) AND IE2 CODE

FOR MAINS VOLTAGE  
460 V - 60 HZ



TEMPERATURE RISE TO CLASS B  
S.F. 1.15

Type	kW	HP	min <sup>-1</sup>	M <sub>N</sub> Nm	IE2 $\eta$			cos $\varphi$	I <sub>N</sub> 460V	I <sub>A</sub> /I <sub>N</sub>	M <sub>A</sub> /M <sub>N</sub>	M <sub>S</sub> /M <sub>N</sub>	M <sub>K</sub> /M <sub>N</sub>	J		
					50%	75%	100%							10 <sup>-3</sup> kgm <sup>2</sup>	kg	
3600 min <sup>-1</sup> (2 poles)																
AMH 80Z AA	2	0.75	1	3480	2.1	77.1	81.5	83.2	0.80	1.5	9.7	4.50	4.5	4.8	1.1	9.5
AMH 80Z BA	2	1.1	1.5	3480	3.0	77.8	81.5	83.3	0.80	2.0	9.6	3.5	3.4	3.7	1.2	11.1
AMH 90S AA	2	1.5	2	3470	4.1	83.8	84.9	84.3	0.88	2.7	10.4	3.1	3	3.6	1.6	14
AMH 90L BA	2	2.2	3	3500	6.0	85.4	86.6	86.3	0.84	3.9	9.8	4.4	4	4.4	1.8	16
AMH 100L AA	2	2.2	3	3530	6.0	86.5	87.9	87.8	0.84	3.9	11.5	4.7	4.1	5.5	3.3	19.7
AMH 100L BA	2	3	4	3525	8.1	86.4	87.8	87.7	0.82	5.0	10.5	5.6	5.3	5.8	4.0	22.8
AMH 112M AA	2	3.7	5	3530	10.0	86.1	88.4	88.1	0.84	6.3	16.5	5.7	2.1	5.8	8.6	33.6
AMH 112M AA	2	4	5.5	3540	10.8	86.1	88.3	88.0	0.87	6.6	15.5	5.3	1.9	5.4	8.6	33.6
AMH 112M BA	2*	5.5	7.5	3500	15.0	85.0	88.6	88.5	0.85	9.3	13.6	4.5	2.5	4.3	8.6	34
AMH 132S ZA	2	5.5	7.5	3520	14.9	86.1	88.2	88.5	0.87	9.2	10.9	3.3	2.9	3.7	20.5	53
AMH 132S TA	2	7.5	10	3510	20.4	89.7	90.1	89.5	0.91	11.0	12.9	3.4	2.9	3.9	20.5	53
AMH 132M TA	2	9.2	12.4	3520	25.0	88.8	89.9	89.5	0.91	14.0	12.1	3.3	2.9	3.9	25	59
AMH 160M YA	2	11	15	3550	29.6	90.1	91.0	91.0	0.88	17.3	13.6	2.8	2.2	3.6	51.7	87.8
AMH 160M ZA	2	15	20	3545	40.4	91.2	89.9	91.0	0.88	23.5	12.2	2.8	2.2	3.6	64	104
AMH 160L ZA	2	18.5	25	3550	49.8	91.5	92.0	91.7	0.87	28.8	12.4	2.8	2.2	3.6	64	105

\* Higher output (progressive motor)

Type	kW	HP	min <sup>-1</sup>	M <sub>N</sub> Nm	IE2 $\eta$			cos $\varphi$	I <sub>N</sub> 460V	I <sub>A</sub> /I <sub>N</sub>	M <sub>A</sub> /M <sub>N</sub>	M <sub>S</sub> /M <sub>N</sub>	M <sub>K</sub> /M <sub>N</sub>	J		
					50%	75%	100%							10 <sup>-3</sup> kgm <sup>2</sup>	kg	
1800 min <sup>-1</sup> (4 poles)																
AMH 80Z AA	4	0.75	1	1740	4.1	77.8	81.5	82.8	0.72	1.6	6.5	3.3	3.4	3.8	2.4	10.6
AMH 90L AA	4	1.1	1.5	1745	6.0	82.2	84.2	84.2	0.76	2.1	8	3.8	4	4.6	3.7	16.4
AMH 90L BA	4	1.5	2	1735	8.3	82.1	84.4	84.4	0.73	3.1	8.7	4	3.9	4.2	3.7	16.4
AMH 90L CA	4	1.8	2.4	1720	10.0	82.2	84.3	84.3	0.77	3.4	8.2	4.4	3.3	4	3.7	16.4
AMH 100L AA	4	2.2	3	1750	12.0	85.8	87.6	87.5	0.70	4.6	8.4	3.8	3.1	3.9	5.6	22.4
AMH 100L BA	4	3	4	1740	16.5	85.7	87.7	87.6	0.76	5.6	9.4	3	2.8	3.2	7.3	26.5
AMH 112M AA	4	3.7	5	1750	20.2	86.3	87.9	87.8	0.79	6.8	6.9	4.2	3.5	4.5	13.3	30.4
AMH 112M AA	4	4	5.5	1745	21.9	86.5	88.1	88	0.81	7.0	6.7	3.9	3.2	4.2	13.3	30.4
AMH 132S ZA	4	5.5	7.5	1755	29.9	88.8	89.8	89.5	0.84	9.4	8.5	3.4	2.8	3.7	30	56
AMH 132M ZA	4	7.5	10	1750	40.9	89.5	90.2	89.5	0.84	12.4	9.1	3.5	2.9	3.8	36	65
AMH 132M TA	4	9.2	12.4	1745	50.3	89.2	90.0	89.5	0.84	16.0	8.8	3.6	2.9	3.9	36	65
AMH 160M ZA	4	11	15	1770	59.3	90.8	91.4	91	0.84	18.5	8.9	3.2	2.3	3.4	105.7	108
AMH 160L ZA	4	15	20	1770	80.9	91.4	91.6	91	0.84	24.0	8.2	3.2	2.3	3.4	120.7	114

# HIGH EFFICIENCY THREE-PHASE MOTORS – IE2

EFFICIENCY LEVEL ACCORDING TO EISA  
EFFICIENCY TESTING METHOD CSA C390-10  
VERIFIED BY UL ENVIRONMENT

NOMINAL FULL LOAD EFFICIENCY ACCORDING TO NEMA MG 1 - TABLE 12-11

FOR MAINS VOLTAGE  
460 V - 60 HZ



TEMPERATURE RISE TO CLASS B  
S.F. 1.15  
IEC - DESIGN H

Type	kW	HP	min <sup>-1</sup>	M <sub>N</sub> Nm	IE2 $\eta$			cos $\varphi$	I <sub>N</sub> 460V	I <sub>A</sub> /I <sub>N</sub>	M <sub>A</sub> /M <sub>N</sub>	M <sub>S</sub> /M <sub>N</sub>	M <sub>K</sub> /M <sub>N</sub>	J 10 <sup>-3</sup> kgm <sup>2</sup>	kg	
					50%	75%	100%									
1200 min <sup>-1</sup> (6 poles)																
AMH 90S AA	6	0.75	1	1145	6.3	78.6	80.5	80.0	0.60	2.0	4.3	2.6	2.3	2.8	6.0	18.1
AMH 90L BA	6	0.9	1.2	1150	7.5	76.0	80.1	80.0	0.56	2.5	5.1	3.1	2.8	3.4	6.5	19.0
AMH 100L AA	6	1.1	1.5	1180	8.9	83.0	85.2	85.5	0.52	3.1	5.8	2.4	1.9	3.9	14.2	26.0
AMH 112M AA	6	1.1	1.5	1175	8.9	84.3	85.6	85.5	0.62	2.5	6.3	3.0	2.5	3.6	12.9	26.7
AMH 112M BA	6	1.5	2	1175	12.2	85.2	86.4	86.5	0.60	3.6	6.0	2.9	2.5	3.5	15.5	29.3
AMH 112M CA	6	2.2	3	1175	17.9	85.2	87.4	87.5	0.60	5.2	6.1	2.8	2.5	3.3	20.1	34.2
AMH 132S YA	6	3	4	1175	24.4	86.2	87.4	87.5	0.64	6.6	6.0	2.3	1.7	3.2	37.7	42.0
AMH 132M YA	6	4	5.5	1170	32.6	86.5	87.6	87.5	0.61	9.2	6.1	2.3	1.7	3.2	44.4	46.0
AMH 132M TA	6	5.5	7.5	1180	44.5	88.0	89.6	89.5	0.55	14.5	6.0	2.3	1.8	3.6	54.1	48.0
AMH 160M ZA	6	7.5	10	1170	61.2	88.1	89.3	89.5	0.77	13.7	8.0	2.8	2.6	3.5	103.0	84.0
AMH 160L TA	6	11	15	1170	89.8	89.1	90.4	90.2	0.78	19.2	8.6	3.1	2.9	4.0	136.0	105.0

# HIGH EFFICIENCY THREE-PHASE MOTORS – IE2

EFFICIENCY LEVEL ACCORDING TO IEC 60034-30:2008  
EFFICIENCY TESTING METHOD IEC 60034-2-1;2007

FOR MAINS VOLTAGE  
400 V - 50 HZ

# IE2

TEMPERATURE RISE TO CLASS B

Type	kW	HP	min <sup>-1</sup>	M <sub>N</sub> Nm	IE2 $\eta$			cos $\varphi$	I <sub>N</sub> 400V	I <sub>A</sub> /I <sub>N</sub>	M <sub>A</sub> /M <sub>N</sub>	M <sub>S</sub> /M <sub>N</sub>	M <sub>K</sub> /M <sub>N</sub>	J	
					50%	75%	100%							10 <sup>-3</sup> kgm <sup>2</sup>	kg
3000 min <sup>-1</sup> (2 poles)															
AMEE 71Z AA	2* 0.75	1	2820	2.5	73.3	76.5	77.5	0.74	1.9	5.5	3.4	3.2	3.4	0.61	7.2
AMEE 80Z AA	2 0.75	1	2825	2.5	71.7	76.1	77.4	0.74	1.9	7.5	4.3	4.1	4.4	0.75	8.4
AMEE 80Z BA	2 1.1	1.5	2820	3.7	77.6	80.0	79.6	0.78	2.5	7.6	4.3	4.1	4.4	0.96	12.0
AMEE 80Z CA	2* 1.5	2	2880	5.0	80.5	82.1	82.3	0.83	3.4	7.7	4.3	4.1	4.4	1.1	13.5
AMEE 90S AA	2 1.5	2	2850	5.0	79.1	81.4	81.3	0.80	3.4	6.8	3.0	3.0	3.1	1.37	12.7
AMEE 90L CA	2 2.2	3	2870	7.3	80.5	83.2	83.6	0.81	4.7	6.8	3.0	3.0	3.2	1.8	16.0
AMEE 90L DA	2* 3	4	2870	10.0	82.4	84.5	84.6	0.79	6.6	6.8	3.4	3.4	3.9	2.1	18.7
AMEE 100L AA	2 3	4	2900	9.9	83.5	84.6	84.6	0.86	5.9	9.8	4.3	3.6	4.0	3.3	19.7
AMEE 100L BA	2* 4	5.5	2910	13.1	85.3	86.7	86.6	0.83	8.0	9.8	4.2	3.6	4.0	4.1	22.8
AMEE 112M AA	2 4	5.5	2900	13.2	82.8	85.2	85.8	0.82	8.3	9.1	3.2	3.2	3.5	12.2	29.5
AMEE 112M BA	2* 5.5	7.5	2920	18.0	85.8	87.4	87.3	0.88	10.4	8.7	3.1	2.6	3.5	8.58	34.0
AMEE 112M CA	2* 7.5	10	2900	24.7	86.5	88.3	88.3	0.92	13.2	9.6	3.4	2.8	3.7	10.5	36.0
AMEE 132S YA	2 5.5	7.5	2910	18.0	85.9	87.8	87.8	0.84	11.0	8.2	2.7	2.7	3.2	10.63	37.0
AMEE 132S ZA	2 7.5	10	2910	24.6	89.3	89.5	88.9	0.86	14.1	8.2	2.7	2.7	3.2	13.8	42.6
AMEE 132M ZA	2 9.2	12.5	2920	30.1	89.1	90.4	89.4	0.90	16.3	9.4	3.0	2.8	4.0	16.0	53.0
AMEE 132M RA	2* 11	15	2920	36.0	88.1	90.0	89.7	0.90	19.8	9.6	3.0	2.9	4.2	17.5	58.0
AMEE 132M TA	2* 15	20	2920	49.1	88.9	90.6	90.3	0.89	27.0	9.6	3.8	2.2	4.0	21.0	61.0
AMEE 160M YA	2 11	15	2935	35.8	87.7	89.4	89.6	0.81	22.0	8.6	3.6	2.8	3.1	40.0	77.0
AMEE 160M ZA	2 15	20	2930	48.9	89.9	90.8	90.3	0.89	26.7	9.2	3.5	2.6	3.3	51.8	77.0
AMEE 160L ZA	2 18.5	25	2930	60.3	89.0	90.6	90.9	0.81	36.3	8.7	3.3	3.1	3.9	53.4	88.9
AMEE 160L TA	2 22	30	2935	71.6	91.0	91.7	91.5	0.90	38.6	9.0	4.4	4.3	3.6	64.0	108.7

\* Higher output (progressive motor)



# HIGH EFFICIENCY THREE-PHASE MOTORS – IE2

EFFICIENCY LEVEL ACCORDING TO IEC 60034-30:2008  
EFFICIENCY TESTING METHOD IEC 60034-2-1;2007

FOR MAINS VOLTAGE  
400 V - 50 HZ

# IE2

TEMPERATURE RISE TO CLASS B

Type	kW	HP	min <sup>-1</sup>	M <sub>N</sub> Nm	IE2 $\eta$			cos $\varphi$	I <sub>N</sub> 400V	I <sub>A</sub> /I <sub>N</sub>	M <sub>A</sub> /M <sub>N</sub>	M <sub>S</sub> /M <sub>N</sub>	M <sub>K</sub> /M <sub>N</sub>	J		
					50%	75%	100%							10 <sup>-3</sup> kgm <sup>2</sup>	kg	
1500 min <sup>-1</sup> (4 poles)																
AMEE 80Z AA	4	0.75	1	1410	5.1	78.6	80.2	80.0	0.80	1.7	6.0	3.0	2.7	2.9	2.3	9.9
AMEE 80Z BA	4*	1.1	1.5	1420	7.4	78.3	81.0	81.4	0.72	2.7	6.0	3.0	2.7	2.9	2.5	11.0
AMEE 90S AA	4	1.1	1.5	1420	7.4	78.5	81.1	81.4	0.72	2.7	7.7	3.8	3.7	3.8	2.7	11.5
AMEE 90L BA	4	1.5	2	1415	10.1	81.3	82.8	82.8	0.70	3.8	7.8	3.9	3.8	4.1	3.1	14.5
AMEE 90L CA	4	1.8	2.4	1420	12.1	84.1	84.9	84.0	0.77	4.0	7.8	3.9	3.8	4.1	3.7	16.4
AMEE 100L AA	4	2.2	3	1440	14.6	83.0	84.6	84.3	0.77	4.9	7.2	3.7	3.2	3.9	5.6	22.5
AMEE 100L BA	4	3	4	1430	20.0	83.7	84.9	85.5	0.74	6.8	7.3	3.7	3.2	3.9	6.05	25.0
AMEE 112M AA	4	4	5.5	1450	26.3	86.0	87.3	87.1	0.78	8.5	7.4	2.6	2.4	3.2	13.3	30.4
AMEE 112M BA	4*	5.5	7.5	1445	36.3	86.8	88.3	88.1	0.78	11.6	8.6	2.8	2.6	3.3	17.4	38.9
AMEE 132S RA	4	5.5	7.5	1455	36.1	86.2	86.9	87.8	0.76	11.8	7.9	3.7	3.5	3.8	26.5	49.0
AMEE 132M TA	4	7.5	10	1450	49.4	87.5	88.8	88.7	0.74	16.4	7.8	3.7	3.5	3.8	36.0	65.0
AMEE 132M ZA	4	9.2	12.4	1450	60.6	86.9	89.2	89.3	0.77	19.5	8.1	3.6	3.5	3.9	42.0	76.0
AMEE 160M ZA	4	11	15	1460	71.9	89.4	90.3	90.1	0.82	22.0	7.9	3.6	2.6	2.7	105.0	108.0
AMEE 160L ZA	4	15	20	1460	98.1	90.6	91.2	91.0	0.84	29.0	7.9	3.6	2.6	2.7	120.7	114.0

\* Higher output (progressive motor)

Type	kW	HP	min <sup>-1</sup>	M <sub>N</sub> Nm	IE2 $\eta$			cos $\varphi$	I <sub>N</sub> 400V	I <sub>A</sub> /I <sub>N</sub>	M <sub>A</sub> /M <sub>N</sub>	M <sub>S</sub> /M <sub>N</sub>	M <sub>K</sub> /M <sub>N</sub>	J		
					50%	75%	100%							10 <sup>-3</sup> kgm <sup>2</sup>	kg	
1000 min <sup>-1</sup> (6 poles)																
AMEE 90S AA	6	0.75	1	925	7.7	75.3	75.8	76.2	0.65	2.2	4.6	1.7	1.6	1.8	4.78	15.0
AMEE 90L BA	6	1.1	1.5	935	11.2	78.5	78.7	78.9	0.67	3.0	4.2	1.8	1.8	2.3	6.45	20.3
AMEE 100L AA	6	1.1	1.5	950	11.1	75.7	77.6	79.5	0.67	3.0	5.5	1.9	1.9	2.4	7.48	19.4
AMEE 100L BA	6	1.5	2	950	15.1	78.5	79.4	79.8	0.69	3.9	5.5	2.1	1.5	2.2	11.6	27.1
AMEE 112M AA	6	2.2	3	960	21.9	79.4	81.0	81.8	0.73	5.3	6.1	3.1	2.2	3.1	18.7	39.0
AMEE 132S YA	6	3	4	960	29.8	82.3	82.9	83.5	0.58	8.9	5.6	2.2	1.4	3.2	37.7	55.8
AMEE 132M YA	6	4	5.5	955	40.0	84.1	84.8	85.2	0.66	10.3	5.8	2.1	1.2	2.9	44.4	65.5
AMEE 132M TA	6	5.5	7.5	970	54.1	85.0	86.2	86.5	0.75	12.2	7.0	1.9	1.1	2.7	54.1	64.1
AMEE 160M YA	6	5.5	7.5	975	53.9	84.7	85.6	86.1	0.78	11.7	7.4	2.3	2.3	3.0	75.2	70.5
AMEE 160M ZA	6	7.5	10	970	73.8	85.8	87.3	87.5	0.78	15.8	7.7	3.0	2.8	3.8	103	96.6
AMEE 160L ZA	6	9.2	12.4	965	91.0	86.3	87.4	88.2	0.83	18.1	8.3	3.1	2.7	3.5	125	103
AMEE 160L TA	6	11	15	965	108.9	87.9	88.2	88.7	0.79	22.5	8.0	2.7	2.4	3.2	156	129

# STANDARD EFFICIENCY THREE-PHASE MOTORS – IE1

EFFICIENCY LEVEL ACCORDING TO IEC 60034-30:2008  
EFFICIENCY TESTING METHOD IEC 60034-2-1;2007

IE code not applicable to motors 2, 4, 6 poles with P<sub>N</sub> ≥ 0.75 kW. Efficiency testing method IEC 60034-2;1996

FOR MAINS VOLTAGE  
400 V - 50 HZ

# IE1

TEMPERATURE RISE TO CLASS B

Type	kW		HP	min <sup>-1</sup>	M <sub>N</sub> Nm	IE1 $\eta$			cos $\varphi$	I <sub>N</sub>		I <sub>A</sub> /I <sub>N</sub>	M <sub>A</sub> /M <sub>N</sub>	M <sub>S</sub> /M <sub>N</sub>	M <sub>K</sub> /M <sub>N</sub>	J	
						50%	75%	100%		400V	380-420V					10 <sup>-3</sup> kgm <sup>2</sup>	kg
3000 min <sup>-1</sup> (2 poles)																	
AM 56Z AA	2	0.09	0.12	2810	0.3	49.0	53.0	59.0	0.67	0.35	0.40	3.9	3.8	3.8	3.9	0.09	3.4
AM 56Z BA	2	0.12	0.16	2800	0.4	51.0	56.0	62.0	0.68	0.40	0.45	3.5	3.4	3.4	3.5	0.10	3.5
AM 63Z AA	2	0.18	0.25	2790	0.6	54	58	63.0	0.73	0.60	0.65	3.7	3.0	3.0	3.1	0.14	3.6
AM 63Z BA	2	0.25	0.33	2790	0.9	57	62	66.0	0.70	0.80	0.75	4.5	3.2	3.2	3.3	0.17	4.1
AM 63Z CA	2*	0.37 <sup>1)</sup>	0.50 <sup>1)</sup>	2800	1.3	54	58	65.0	0.70	1.20	1.25	4.6	3.4	3.3	3.4	0.20	4.4
AM 71Z AA	2	0.37	0.50	2820	1.3	58.0	64.0	70.0	0.78	1.0	1.2	4.7	3.6	3.4	3.6	0.32	5.8
AM 71Z BA	2	0.55	0.75	2830	1.9	57.0	64.0	71.0	0.77	1.5	1.6	4.8	3.2	3.1	3.3	0.37	6.2
AM 71Z CA	2*	0.75 <sup>1)</sup>	1 <sup>1)</sup>	2800	2.6	58.9	65.7	72.6	0.76	2.0	2.1	5.2	3.1	3.2	3.1	0.48	7.2
AM 80Z AA	2	0.75	1	2840	2.5	66.3	71.5	73.0	0.78	1.9	2.0	5.0	2.8	2.8	2.9	0.6	8.4
AM 80Z BA	2	1.1	1.5	2810	3.7	72.1	75.0	75.3	0.82	2.5	2.6	4.6	2.4	2.8	2.9	0.75	9.5
AM 80Z CA	2*	1.5 <sup>1)</sup>	2 <sup>1)</sup>	2825	5.1	74.7	77.5	77.8	0.83	3.3	3.4	5.0	2.9	3.0	3.3	1.92	11.1
AM 90S AA	2	1.5	2	2830	5.1	75.6	78.7	78.6	0.82	3.4	3.5	5.0	3.1	2.9	3.0	1.23	12.7
AM 90S BA	2*	1.8	2.5	2805	6.1	74.9	78.0	78.2	0.80	4.2	4.3	4.5	2.6	2.4	2.5	1.23	12.7
AM 90L CA	2	2.2	3	2860	7.3	81.5	82.8	81.8	0.81	4.9	4.9	7.1	4.1	3.6	4.0	1.68	16.0
AM 90L DA	2*	3 <sup>1)</sup>	4 <sup>1)</sup>	2860	10.0	78.7	81.8	82.2	0.80	6.6	6.8	7.2	3.9	3.4	3.8	2.16	18.7
AM 100L AA	2	3	4	2860	10.0	78.9	81.4	81.5	0.85	6.4	6.7	6.0	3.1	3.1	3.3	2.36	19.3
AM 100L BA	2*	4 <sup>1)</sup>	5.5 <sup>1)</sup>	2835	13.5	81.1	82.5	81.7	0.88	8.0	8.1	6.2	2.9	2.5	2.9	2.90	19.7
AM 100L CA	2*	5.5 <sup>1)</sup>	7.5 <sup>1)</sup>	2865	18.3	83.7	84.6	83.3	0.86	11.1	11.3	7.2	3.5	3.4	4.1	3.90	25.9
AM 112M AA	2	4	5.5	2880	13.3	81.9	84.0	83.5	0.82	8.4	8.7	8.0	3.4	3.5	3.6	4.65	24.3
AM 112M BA	2*	5.5	7.5	2900	18.1	83.6	84.7	85.0	0.86	10.9	11.2	7.8	3.5	3.4	3.6	5.80	27.4
AM 112M CA	2*	7.5	10	2900	24.7	86.7	87.8	87.1	0.87	14.3	14.8	8.7	4.0	3.9	4.0	8.50	33.6
AM 132S YA	2	5.5	7.5	2890	18.2	83.2	84.7	85.0	0.83	11.3	11.4	6.0	2.2	2.1	2.3	9.50	37.0
AM 132S ZA	2	7.5	10	2880	24.9	85.6	86.7	86.1	0.87	14.5	14.9	6.4	2.9	2.7	3.1	12.30	42.6
AM 132M ZA	2*	9.2	12.5	2900	30.3	84.7	86.8	87.0	0.84	18.4	18.8	7.0	2.8	2.4	3.2	13.20	48.0
AM 132M RA	2*	11	15	2880	36.5	87.1	88.1	88.0	0.85	21.3	21.7	6.9	3.2	2.8	3.8	16.00	52.5
AM 132M TA	2*	15 <sup>1)</sup>	20 <sup>1)</sup>	2920	49.1	86.4	88.6	88.9	0.83	29.5	30.5	7.0	3.2	2.8	3.7	21.20	59.0
AM 160M VA	2	11	15	2940	35.7	83.4	86.4	87.7	0.83	21.9	22.7	7.4	2.5	2.3	3.1	33.10	77.0
AM 160M XA	2	15	20	2940	48.7	87.3	88.9	88.9	0.85	28.6	29.2	8.1	3.1	2.6	3.7	43.90	94.0
AM 160L XA	2	18.5	25	2950	59.9	88.2	89.7	89.6	0.87	34.3	34.8	8.5	3.6	3.0	4.2	57.00	107.8
AM 160L RA	2*	22	30	2940	71.5	88.7	90.5	90.4	0.90	39.1	39.4	8.4	3.0	2.6	3.7	57.00	108.7

1) Temperature rise to class F  
\* Higher output (progressive motor)

# STANDARD EFFICIENCY THREE-PHASE MOTORS – IE1

EFFICIENCY LEVEL ACCORDING TO IEC 60034-30:2008  
EFFICIENCY TESTING METHOD IEC 60034-2-1;2007

IE code not applicable to motors 2, 4, 6 poles with PN  $\geq$  0.75 kW. Efficiency testing method IEC 60034-2;1996

FOR MAINS VOLTAGE  
400 V - 50 HZ

# IE1

TEMPERATURE RISE TO CLASS B

Type	kW	HP	min <sup>-1</sup>	M <sub>N</sub> Nm	IE1 $\eta$			cos $\varphi$	I <sub>N</sub>		I <sub>A</sub> /I <sub>N</sub>	M <sub>A</sub> /M <sub>N</sub>	M <sub>S</sub> /M <sub>N</sub>	M <sub>K</sub> /M <sub>N</sub>	J		
					50%	75%	100%		400V	380-420V					10 <sup>3</sup> kgm <sup>2</sup>	kg	
1500 min <sup>-1</sup> (4 poles)																	
AM 56Z AA	4	0.06	0.08	1300	0.4	42.0	44.0	48.0	0.70	0.28	0.32	2.6	2.1	2.0	2.1	0.14	2.7
AM 56Z BA	4	0.09	0.12	1330	0.6	43.0	47.0	51.0	0.74	0.35	0.40	2.5	2.2	2.1	2.2	0.16	2.9
AM 63Z AA	4	0.12	0.16	1350	0.8	46.0	50.0	57.0	0.65	0.50	0.55	2.4	2.0	1.9	2.0	0.25	3.3
AM 63Z BA	4	0.18	0.25	1330	1.3	47.0	50.0	58.0	0.70	0.65	0.70	2.3	1.9	1.8	1.9	0.27	4.1
AM 63Z CA	4*	0.25	0.33	1360	1.8	49.0	52.5	58.0	0.74	0.85	0.90	2.7	2.2	2.0	2.1	0.30	4.2
AM 71Z AA	4	0.25	0.33	1340	1.8	55.0	59.0	64.0	0.66	0.90	1.00	3.2	1.9	1.8	2.0	0.65	5.7
AM 71Z BA	4	0.37	0.50	1370	2.6	60.0	63.0	67.0	0.67	1.20	1.25	3.3	2.2	2.1	2.2	0.76	6.0
AM 71Z CA	4*	0.55 <sup>1)</sup>	0.75 <sup>1)</sup>	1380	3.8	61.0	64.0	69.0	0.68	1.70	1.80	3.6	2.4	2.3	2.4	1.00	7.3
AM 80Z AA	4	0.55	0.75	1400	3.8	67.0	69.0	70.0	0.72	1.6	1.7	3.6	2.6	2.5	2.6	1.38	8.2
AM 80Z BA	4	0.75	1	1410	5.1	68.7	70.8	72.4	0.72	2.1	2.2	4.4	2.8	2.3	2.8	1.78	9.3
AM 80Z CA	4*	1.1 <sup>1)</sup>	1.5 <sup>1)</sup>	1385	7.6	73.4	75.7	75.2	0.77	2.8	2.9	4.4	2.5	2.5	2.6	2.18	10.6
AM 90S AA	4	1.1	1.5	1400	7.5	75.8	76.0	75.4	0.78	2.7	2.9	5.2	2.5	2.4	2.8	2.20	12.5
AM 90L BA	4	1.5	2	1400	10.2	77.6	77.8	77.5	0.78	3.6	3.7	5.7	2.8	2.6	3.0	2.80	14.5
AM 90L CA	4	1.8 <sup>1)</sup>	2.5 <sup>1)</sup>	1380	12.5	76.3	76.5	75.9	0.81	4.2	4.3	5.5	2.7	2.5	2.9	3.35	14.5
AM 90L DA	4*	2.2 <sup>1)</sup>	3 <sup>1)</sup>	1400	15.0	78.3	78.5	77.9	0.77	5.3	5.5	4.8	2.9	2.8	3.2	3.65	17.0
AM 100L AA	4	2.2	3	1435	14.6	76.5	79.1	79.9	0.74	5.4	5.6	5.3	2.5	2.4	2.7	4.50	19.5
AM 100L BA	4	3	4	1425	20.1	82.0	83.0	81.6	0.78	6.8	6.9	4.6	2.4	2.3	2.5	5.75	22.5
AM 100L CA	4*	4 <sup>1)</sup>	5.5 <sup>1)</sup>	1400	27.3	80.8	81.8	80.4	0.78	9.2	9.3	6.0	2.6	2.4	2.9	6.30	25.0
AM 112M AA	4	4	5.5	1430	26.7	83.2	83.9	83.1	0.82	8.5	8.8	6.3	2.2	2.0	2.8	10.70	29.5
AM 112M BA	4*	5.5 <sup>1)</sup>	7.5 <sup>1)</sup>	1430	36.7	84.1	84.8	84.0	0.83	11.4	11.7	6.5	2.2	2.0	2.9	13.50	34.0
AM 132S ZA	4	5.5	7.5	1430	36.7	87.2	87.1	86.1	0.82	11.3	11.7	5.8	3.0	2.7	3.0	21.20	41.9
AM 132M ZA	4	7.5	10	1440	49.7	87.3	87.2	86.2	0.83	15.3	15.5	6.8	3.1	2.7	3.1	27.80	51.0
AM 132M RA	4	9.2	12.5	1440	61.0	86.5	87.5	87.3	0.86	17.7	17.9	8.0	3.5	3.2	3.5	31.50	65.0
AM 132M TA	4*	11.0 <sup>1)</sup>	15 <sup>1)</sup>	1440	72.9	83.5	83.9	84.5	0.87	21.5	22.0	8.3	3.1	3.0	3.3	31.50	65.0
AM 160M XA	4	11	15	1460	71.9	88.5	89.3	88.7	0.80	22.4	22.7	7.5	2.5	2.2	3.1	66.8	88.5
AM 160L XA	4	15	20	1460	98.1	89.4	90.2	89.6	0.84	28.8	29.6	7.0	2.5	2.2	3.3	87.8	106.5
AM 160L ZA	4*	18.5	25	1460	121.8	89.9	90.7	90.1	0.84	35.4	36	7.6	2.5	2.2	3.3	100.50	117.3
AM 160L RA	4*	22	30	1460	143.9	90.4	91.2	90.6	0.86	41.0	42	7.8	2.4	2.2	3.2	112.50	128.1

1) Temperature rise to class F

\* Higher output (progressive motor)

# STANDARD EFFICIENCY THREE-PHASE MOTORS – IE1

EFFICIENCY LEVEL ACCORDING TO IEC 60034-30:2008  
EFFICIENCY TESTING METHOD IEC 60034-2-1;2007

IE code not applicable to motors 2, 4, 6 poles with PN  $\geq$  0.75 kW. Efficiency testing method IEC 60034-2;1996

FOR MAINS VOLTAGE  
400 V - 50 HZ

# IE1

TEMPERATURE RISE TO CLASS B

Type	kW	HP	min <sup>-1</sup>	M <sub>N</sub> Nm	IE1 $\eta$			cos $\varphi$	I <sub>N</sub>		I <sub>A</sub> /I <sub>N</sub>	M <sub>A</sub> /M <sub>N</sub>	M <sub>S</sub> /M <sub>N</sub>	M <sub>K</sub> /M <sub>N</sub>	J		
					50%	75%	100%		400V	380-420V					10 <sup>-3</sup> kgm <sup>2</sup>	kg	
1000 min <sup>-1</sup> (6 poles)																	
AM 71Z AA	6	0.18	0.25	880	2.0	46.0	48.0	53.0	0.60	0.85	0.9	2.2	1.6	1.5	1.6	1.00	6.1
AM 71Z BA	6	0.25 <sup>1)</sup>	0.33 <sup>1)</sup>	880	2.7	46.0	50.0	54.0	0.62	1.10	1.2	2.5	1.7	1.6	1.7	1.19	6.6
AM 80Z AA	6	0.37	0.5	920	3.8	47.0	58.0	60.0	0.70	1.25	1.3	2.7	1.6	1.6	2.1	1.83	8.0
AM 80Z BA	6	0.55	0.75	920	5.7	60.0	64.0	68.0	0.67	1.75	1.8	2.9	2.2	2.1	2.1	2.36	9.4
AM 90S AA	6	0.75	1	910	7.9	70.5	72.5	71.5	0.63	2.4	2.5	2.9	1.7	1.5	1.7	2.90	11.6
AM 90L BA	6	1.1	1.5	920	11.4	72.0	73.5	73.0	0.66	3.3	3.4	3.0	1.7	1.5	1.7	4.38	15.0
AM 100L AA	6	1.5	2	930	15.4	73.3	75.8	75.3	0.69	4.2	4.4	3.7	1.8	1.8	2.3	6.35	17.5
AM 100L BA	6	1.8	2.5	940	18.3	74.6	77.1	76.6	0.67	5.1	5.3	4.2	2.4	2.4	2.8	9.00	22.0
AM 112M AA	6	2.2	3	940	22.4	77.0	79.0	78.0	0.74	5.3	5.4	4.4	2.4	2.4	2.6	12.85	26.0
AM 112M CA	6*	3	4	940	30.5	81.8	82.8	82.8	0.74	7.0	7.2	5.3	2.9	2.9	2.9	17.90	39.0
AM 132S ZA	6	3	4	950	30.2	79.5	81.5	81.3	0.72	7.4	7.5	4.9	2.0	1.8	2.4	21.40	36.7
AM 132M YA	6	4	5.5	950	40.2	81.4	83.1	82.7	0.71	9.9	10.5	4.5	2.2	2.0	2.5	28.90	42.5
AM 132M ZA	6	5.5	7.5	950	55.3	82.2	83.6	83.6	0.71	13.5	13.5	4.1	2.2	1.9	2.2	37.40	55.5
AM 132M TA	6*	7.5 <sup>1)</sup>	10 <sup>1)</sup>	960	74.6	82.8	83.5	82.9	0.75	17.4	17.6	5.0	2.3	1.9	2.8	46.70	64.1
AM 160M ZA	6	7.5	10	970	73.8	84.4	86.5	86.3	0.78	16.0	16.3	6.2	2.8	2.7	3.2	103	96.6
AM 160L ZA	6	11	15	960	109.4	88.1	88.5	87.8	0.78	23.4	24.0	6.0	2.5	2.2	3.5	136	113.6

1) Temperature rise to class F

\* Higher output (progressive motor)

EFFICIENCY TESTING METHOD IEC 60034-2-1;1996

Type	kW	HP	min <sup>-1</sup>	M <sub>N</sub> Nm	$\eta$			cos $\varphi$	I <sub>N</sub>		I <sub>A</sub> /I <sub>N</sub>	M <sub>A</sub> /M <sub>N</sub>	M <sub>S</sub> /M <sub>N</sub>	M <sub>K</sub> /M <sub>N</sub>	J		
					50%	75%	100%		400V	380-420V					10 <sup>-3</sup> kgm <sup>2</sup>	kg	
750 min <sup>-1</sup> (8 poles)																	
AM 71Z AA	8	0.12	0.16	670	1.7	40	44	50	0.55	0.65	0.7	2.4	2.5	2.4	2.5	0.76	6.0
AM 80Z AA	8	0.25	0.33	680	3.5	40	47	51	0.62	1.1	1.2	2.2	1.8	1.9	2.0	1.83	8.0
AM 90S AA	8	0.37	0.5	680	5.2	52	58	59	0.53	1.7	1.8	2.1	1.4	1.3	1.6	2.91	11.4
AM 90L BA	8	0.55	0.75	680	7.7	52	58	59	0.54	2.5	2.7	2.1	1.4	1.3	1.6	4.40	15.0
AM 100L AA	8	0.75	1	690	10.4	59	64	65	0.65	2.6	2.8	3.0	1.6	1.5	1.7	6.35	17.6
AM 100L BA	8	1.1	1.5	690	15.2	59	67	68	0.62	3.9	4.0	3.0	1.9	1.3	1.6	9.00	22.6
AM 112M AA	8	1.5	2	696	20.6	66	69	70	0.66	4.6	4.8	4.0	1.8	2.0	2.4	15.35	35.0
AM 132S ZA	8	2.2	3	710	29.6	79.3	80.5	78.8	0.64	6.4	6.6	3.4	1.7	1.6	1.7	28.90	45.5
AM 132M ZA	8	3	4	710	40.4	81.3	82.0	79.8	0.67	8.1	9.2	3.6	1.7	1.6	1.9	37.40	54.5
AM 160M YA	8	4	5.5	700	54.6	84.9	84.5	84.4	0.72	9.5	9.7	4.5	1.8	1.6	2.2	76.70	75.0
AM 160M ZA	8	5.5	7.5	720	72.9	85.6	85.2	85.0	0.73	12.8	13.3	4.0	1.8	1.6	2.3	103.70	92.0
AM 160L ZA	8	7.5	10	710	100.9	86.3	85.8	85.5	0.74	17.1	17.8	4.0	1.8	1.6	2.3	136.00	113

## THREE-PHASE TWO SPEED MOTORS

DESIGNED FOR RANGE  
OF RATED VOLTAGE  
380-420 V ± 5% - 50 HZ

FOR MAINS VOLTAGE  
400 V - 50 HZ

TEMPERATURE RISE TO CLASS B

Type	kW	HP	min <sup>-1</sup>	M <sub>N</sub> Nm	η 100%	cos φ	I <sub>N</sub>		I <sub>A</sub> /I <sub>N</sub>	M <sub>A</sub> /M <sub>N</sub>	J		
							400V	380-420V			10 <sup>-3</sup> kgm <sup>2</sup>	kg	
1500/3000 min <sup>-1</sup> (4/2 poles) - Dahlander connection Δ/YY													
AM 63Z AA	4/2	0.20/0.30	0.27/0.40	1345/2700	1.4/1.1	56/65	0.65/0.81	0.8/0.83	0.89/0.88	2.4/3.2	2.1/2.1	0.40	4.6
AM 71Z AA	4/2	0.30/0.45	0.40/0.65	1374/2830	2.1/1.5	61/66	0.78/0.73	1.0/1.35	1.2/1.5	3.3/3.0	2.3/2.1	0.76	6.3
AM 80Z AA	4/2	0.45/0.60	0.65/0.80	1390/2760	3.1/2.1	64/68.8	0.75/0.80	1.4/1.6	1.5/1.7	3.8/4.0	2.3/2.2	1.58	8.3
AM 80Z BA	4/2	0.55/0.75	0.75/1.0	1435/2850	3.7/2.5	70/71.2	0.67/0.77	1.7/2.0	1.8/2.1	4.5/5.0	2.6/2.8	2.00	11.5
AM 80Z CA	4/2	0.8/1.1	1.1/1.5	1425/2830	5.4/3.7	76.1/77.2	0.70/0.79	2.2/2.6	2.5/2.8	4.5/4.9	2.5/2.7	2.41	14.7
AM 90L AA	4/2	1.2/1.55	1.6/2.1	1435/2850	8/5.2	77.4/78.3	0.71/0.79	3.2/3.7	3.4/3.9	4.7/5.1	2.6/2.7	3.10	15.6
AM 90L BA	4/2	1.6/2.0 <sup>1)</sup>	2.15/2.7 <sup>1)</sup>	1390/2810	11/6.8	73.5/75.5	0.78/0.86	4.0/4.6	4.1/4.7	4.1/5.5	2.7/2.6	3.73	17.1
AM 100L AA	4/2	1.8/2.5	2.5/3.35	1420/2865	12.1/8.3	78.5/77.4	0.76/0.84	4.5/5.6	4.7/5.8	5.2/5.5	2.2/2.2	4.60	21.4
AM 100L BA	4/2	2.2/3.0	3.0/4.0	1410/2830	14.9/10.1	74.6/71.4	0.72/0.82	5.9/7.4	6.1/7.7	4.2/4.3	1.8/2.0	4.60	22.5
AM 100L CA	4/2	2.6/3.3	3.5/4.4	1430/2890	17.4/10.9	82.6/78.6	0.78/0.76	5.9/8.0	6.1/8.5	4.7/5.5	1.9/2.2	5.58	23.2
AM 112M AA	4/2	3.3/4.4	4.4/5.9	1410/2800	22.4/15	77.4/75.4	0.82/0.85	7.5/9.9	7.8/10.6	4.5/5.1	2.1/2.4	13.30	36.1
AM 132S ZA	4/2	4.4/5.5	6.0/7.5	1450/2925	29/18	83.0/84.6	0.70/0.87	11.0/10.8	12.0/11.8	4.4/7.2	2.2/2.7	13.83	42.6
AM 132M ZA	4/2	6.6/8.1	9.0/11.0	1460/2920	43.2/26.5	85.4/84.5	0.76/0.90	14.7/15.4	15.5/16.4	5.5/7.5	2.6/2.9	17.13	51.4
AM 160M ZA	4/2	8.8/11.0	12.0/15.0	1460/2940	57.6/35.7	87.1/87.5	0.79/0.91	18.5/20.0	19.0/21.0	5.5/7.5	2.0/1.9	51.75	94.0
AM 160L ZA	4/2	12.5/15.0	17.0/20.4	1470/2955	81.2/48.5	89.4/90.0	0.74/0.90	27.4/26.8	29.0/28.2	4.8/7.4	2.1/2.3	64.00	108.7

Type	kW	HP	min <sup>-1</sup>	M <sub>N</sub> Nm	η 100%	cos φ	I <sub>N</sub>		I <sub>A</sub> /I <sub>N</sub>	M <sub>A</sub> /M <sub>N</sub>	J		
							400V	380-420V			10 <sup>-3</sup> kgm <sup>2</sup>	kg	
750/1500 min <sup>-1</sup> (8/4 poles) - Dahlander connection Δ/YY													
AM 71Z AA	8/4	0.09/0.15	0.12/0.20	610/1310	1.4/1.1	40/56	0.61/0.75	0.53/0.52	0.59/0.57	2.5/3.2	1.6/1.6	0.71	6.3
AM 80Z AA	8/4	0.18/0.37	0.25/0.50	700/1370	2.5/2.6	43.2/58.7	0.63/0.83	1.0/1.1	1.1/1.2	2.6/3.4	1.8/1.6	1.97	7.9
AM 80Z BA	8/4	0.26/0.51	0.35/0.68	700/1360	3.5/3.6	44.1/61.2	0.60/0.88	1.2/1.4	1.3/1.5	2.5/3.6	2.0/1.6	2.47	9.2
AM 90S AA	8/4	0.37/0.75	0.50/1.0	690/1385	5.1/5.2	52.2/67.1	0.58/0.82	1.8/2.0	1.9/2.1	2.8/3.9	1.9/1.8	3.18	13.5
AM 90L BA	8/4	0.5/1.0	0.67/1.34	690/1410	6.9/6.8	52.2/72.5	0.58/0.80	2.4/2.4	2.5/2.5	3.3/4.0	2.3/1.9	4.78	15.7
AM 100L AA	8/4	0.7/1.4	0.94/1.9	700/1440	9.5/9.3	57.2/78.5	0.50/0.78	3.5/3.3	3.7/3.4	2.8/4.3	2.1/1.9	5.58	21.9
AM 100L BA	8/4	0.9/1.8 <sup>1)</sup>	1.2/2.5 <sup>1)</sup>	690/1415	12.5/12.1	62/76	0.56/0.87	3.8/4.0	4.0/4.3	2.5/4.5	1.9/1.8	6.00	23.7
AM 112M AA	8/4	1/1.8	1.34/2.5	710/1445	13.5/11.9	66.1/78.5	0.61/0.82	4.1/4.1	4.4/4.2	3.9/6.3	2.2/2.1	14.18	31.7
AM 112M BA	8/4	1.3/2.6 <sup>1)</sup>	1.75/3.0 <sup>1)</sup>	705/1420	17.6/17.5	70.0/76.3	0.65/0.88	4.6/5.7	4.8/5.9	3.2/4.8	2.1/2.0	16.70	34.2
AM 132S ZA	8/4	2.1/3.7	2.9/5.0	710/1440	28.2/24.5	70.2/76.1	0.66/0.84	6.5/8.4	6.7/8.6	4.0/5.2	1.9/1.7	29.50	42.5
AM 132M ZA	8/4	2.6/4.8	3.5/6.5	715/1450	34.7/31.6	71.6/78.8	0.60/0.80	8.8/11.0	9.8/12.0	4.3/5.5	2.3/1.8	37.75	55.5
AM 160M YA	8/4	4.0/6.3	5.5/8.6	710/1410	53.8/42.7	80.0/81.0	0.64/0.88	11.3/12.8	12.3/13.5	4.6/6.5	1.8/1.7	81.25	88.5
AM 160L YA	8/4	4.8/7.5	6.5/10.0	730/1470	62.8/48.7	80.0/85.0	0.65/0.85	13.2/15.0	14.0/16.0	4.5/6.5	1.8/1.6	105.75	106.5
AM 160L ZA	8/4	5.9/10.3	8.0/14.0	725/1450	77.7/67.8	81.0/87.0	0.66/0.88	16.1/19.5	17.0/20.4	5.0/6.0	1.9/1.6	127.50	110.5

1) Temperature rise to class F

## THREE-PHASE TWO SPEED MOTORS

DESIGNED FOR RANGE  
OF RATED VOLTAGE  
380-420 V  $\pm$  5% - 50 HZ

FOR MAINS VOLTAGE  
400 V - 50 HZ

TEMPERATURE RISE TO CLASS B

Type	kW	HP	min <sup>-1</sup>	M <sub>N</sub> Nm	$\eta$ 100%	cos $\varphi$	I <sub>N</sub>		I <sub>A</sub> /I <sub>N</sub>	M <sub>A</sub> /M <sub>N</sub>	J		
							400V	380-420V			10 <sup>-3</sup> kgm <sup>2</sup>	kg	
1500/1000 min <sup>-1</sup> (4/6 poles) - separate windings													
AM 71Z AA	4/6	0.22/0.15	0.30/0.20	1430/900	1.5/1.6	61/44	0.7/0.64	0.78/0.68	0.83/0.73	1.9/3.4	1.5/1.8	0.73	6.2
AM 80Z AA	4/6	0.37/0.26	0.50/0.35	1385/905	2.6/2.7	61.4/48.1	0.82/0.80	1.1/1.0	1.1/1.1	3.7/2.6	1.7/1.3	1.97	8.3
AM 80Z BA	4/6	0.55/0.37	0.75/0.50	1380/900	3.8/3.9	60.5/51.1	0.64/0.82	1.5/1.3	1.6/1.4	3.7/2.7	1.6/1.2	2.47	10.0
AM 90S AA	4/6	0.75/0.5	1.0/0.67	1400/930	5.1/5.1	63/64	0.81/0.61	2.2/1.9	2.3/2.1	3.0/3.5	1.4/1.8	4.10	13.4
AM 90L BA	4/6	1.0/0.65	1.34/0.87	1380/920	6.9/6.7	68.8/67.1	0.81/0.62	2.6/2.3	2.8/2.5	2.9/3.4	1.1/1.6	4.78	16.4
AM 100L AA	4/6	1.2/0.8	1.6/1.07	1460/940	7.8/8.1	76.0/67.9	0.66/0.70	3.5/2.5	3.8/2.6	4.7/3.0	2.1/1.5	4.60	24.4
AM 100L BA	4/6	1.6/1.0	2.15/1.34	1445/935	10.6/10.2	77.6/69.5	0.73/0.63	4.1/3.3	4.3/3.5	5.8/3.0	2.8/1.7	5.58	33.2
AM 112M AA	4/6	1.8/1.3	2.5/1.75	1445/950	11.9/13.1	74.6/69.5	0.85/0.78	4.2/3.6	4.4/3.7	5.9/3.8	1.9/1.3	14.18	33.3
AM 112M BA	4/6	2.6/1.85	3.5/2.5	1445/950	17.2/18.6	73.8/71.6	0.86/0.73	6.0/5.2	6.2/5.4	6.1/4.4	2.0/1.7	17.53	37.0
AM 132S ZA	4/6	3.1/2.2	4.2/3.0	1440/965	20.6/21.8	80/78	0.80/0.74	7/5.5	7.5/6	5.8/5.6	2.1/2.0	22.4	41.9
AM 132M ZA	4/6	4.0/2.6	5.5/3.5	1470/975	26/25.5	81.0/79.3	0.83/0.74	8.6/6.4	9.3/7.0	7.7/5.2	2.0/1.9	29.25	51.0
AM 160M YA	4/6	5.5/3.7	7.5/5.0	1480/970	35.5/36.4	84.0/81.4	0.79/0.73	12.0/9.0	12.9/9.6	7.5/4.5	2.5/1.6	81.25	88.5
AM 160M ZA	4/6	7.5/4.8	10.2/6.5	1465/960	48.9/47.7	85.0/82.6	0.83/0.75	15.4/11.2	15.8/11.5	7.4/4.6	2.4/1.6	81.25	88.5
AM 160L ZA	4/6	11.0/6.6	15.0/9.0	1470/960	71.5/65.7	86.0/83.8	0.86/0.75	21.6/15.2	22.5/16.0	7.2/5.0	2.3/1.8	105.75	106.5

Type	kW	HP	min <sup>-1</sup>	M <sub>N</sub> Nm	$\eta$ 100%	cos $\varphi$	I <sub>N</sub>		I <sub>A</sub> /I <sub>N</sub>	M <sub>A</sub> /M <sub>N</sub>	J		
							400V	380-420V			10 <sup>-3</sup> kgm <sup>2</sup>	kg	
1000/750 min <sup>-1</sup> (6/8 poles) - separate windings													
AM 80Z AA	6/8	0.37/0.18	0.50/0.25	915/700	3.9/2.5	51.1/44.2	0.81/0.65	1.3/1.0	1.4/1.0	2.8/2.5	1.4/1.7	2.47	9.5
AM 90L AA	6/8	0.55/0.30	0.75/0.40	950/710	5.5/4	65.2/45.1	0.62/0.52	2.0/1.8	2.1/1.9	3.9/2.6	2.5/1.9	4.78	16.2
AM 100L AA	6/8	0.75/0.45	1.0/0.60	960/720	7.5/6	72.6/61.8	0.67/0.54	2.2/2.0	2.3/2.1	4.1/2.9	1.9/1.9	6.73	23.4
AM 112M AA	6/8	0.95/0.65	1.3/0.90	965/715	9.4/8.7	65.2/62.1	0.78/0.70	3.0/2.2	3.2/2.3	4.5/3.8	1.4/1.7	14.18	32.0
AM 112M BA	6/8	1.5/0.75	2.0/1.0	970/720	14.8/9.9	75.3/64.6	0.66/0.60	4.4/2.8	4.6/3.0	4.6/3.8	2.2/2.1	18.70	36.2
AM 132S ZA	6/8	2.2/1.2	3.0/1.6	970/730	21.7/15.7	73.5/66.0	0.69/0.60	6.3/4.4	6.6/4.8	4.5/3.7	1.6/1.7	29.5	42.5
AM 132M ZA	6/8	3.0/1.7	4.1/2.3	980/730	29.2/22.2	78.2/72.5	0.72/0.64	7.7/5.3	8.2/5.9	5.4/4.3	1.7/1.7	37.75	55.5
AM 160M YA	6/8	4.8/2.6	6.5/3.5	970/730	47.3/34	83.0/74.0	0.80/0.70	10.5/7.3	11.0/7.7	4.8/3.6	1.9/1.8	112.7	88.0
AM 160M ZA	6/8	5.9/3.3	8.0/4.5	970/730	58.1/43.2	83.2/73.0	0.76/0.60	13.5/10.9	14.5/11.4	6.5/5.0	2.2/2.1	150.25	97.5

# THREE-PHASE TWO SPEED MOTORS FOR CENTRIFUGAL MACHINES

DESIGNED FOR RANGE  
OF RATED VOLTAGE  
380-420 V ± 5% - 50 HZ

FOR MAINS VOLTAGE  
400 V - 50 HZ

TEMPERATURE RISE TO CLASS B

Type	kW	HP	min <sup>-1</sup>	M <sub>N</sub> Nm	η 100%	cos φ	I <sub>N</sub>		I <sub>A</sub> /I <sub>N</sub>	M <sub>A</sub> /M <sub>N</sub>	J		
							400V	380-420V			10 <sup>-3</sup> kgm <sup>2</sup>	kg	
1500/3000 min <sup>-1</sup> (4/2 poles) - Dahlander connection Y/YY													
AMV 63Z AA	4/2	0.07/0.33	0.095/0.45	1350/2700	0.5/1.2	55/60	0.70/0.80	0.25/0.95	0.27/1.1	2.5/2.6	1.8/1.6	0.37	5.0
AMV 71Z AA	4/2	0.08/0.37	0.11/0.5	1350/2870	0.6/1.2	60/64	0.65/0.68	0.30/1.3	0.35/1.4	3.2/4.3	2.0/2.8	0.82	7.9
AMV 71Z BA	4/2	0.12/0.55	0.16/0.75	1430/2835	0.8/1.9	70/68	0.65/0.72	0.40/1.6	0.42/1.7	4.1/4.0	3/2.8	1.08	10.0
AMV 80Z AA	4/2	0.15/0.75	0.2/1.0	1400/2710	1/2.6	70/68	0.68/0.80	0.45/1.9	0.45/2.0	2.6/4.6	2.8/2.9	1.58	8.3
AMV 80Z BA	4/2	0.22/1.1	0.3/1.5	1420/2820	1.5/3.7	70/73	0.75/0.84	0.6/2.5	0.65/2.6	4.6/4.7	2.7/2.9	2.0	11.5
AMV 90L AA	4/2	0.30/1.5	0.4/2.0	1400/2830	2/5.1	69/70	0.70/0.84	0.9/3.5	1.0/3.7	4.7/5.0	2.7/3.0	3.13	15.6
AMV 90L BA	4/2	0.44/2.2	0.6/3.0	1430/2830	2.9/7.4	74/72	0.76/0.89	1.1/4.8	1.2/5.0	4.5/5.2	2.6/2.8	3.73	17.1
AMV 100L AA	4/2	0.50/2.5	0.67/3.3	1430/2840	3.3/8.4	72/73	0.77/0.88	1.3/5.3	1.4/5.6	4.6/5.0	2.2/2.3	4.6	21.4
AMV 100L BA	4/2	0.60/3.0	0.8/4.0	1440/2850	4/10.1	78/77	0.79/0.87	1.3/6.2	1.4/6.5	4.5/4.5	2.2/2.1	5.58	23.2
AMV 112M AA	4/2	0.75/3.70	1.0/5.0	1440/2850	5/12.4	74/72	0.80/0.90	1.7/7.9	1.9/2.2	4.5/5.1	2.0/2.4	13.3	36.1
AMV 112M BA	4/2	0.9/4.5	1.2/6.1	1440/2850	6/15.1	75/73	0.82/0.90	2.0/9.5	2.1/9.8	4.5/5.5	2.0/2.3	14.75	40.0
AMV 132S AA	4/2	1.1/5.5	1.5/7.5	1440/2880	7.3/18.2	81.5/84.8	0.78/0.90	2.5/10.4	2.6/11.0	5.0/6.0	2.1/2.8	13.83	42.6
AMV 132S BA	4/2	1.5/7 <sup>1)</sup>	2/9.5 <sup>1)</sup>	1440/2900	9.9/23.1	82.0/86.0	0.78/0.92	3.4/12.8	3.8/13.0	5.3/6.5	2.2/2.9	13.83	42.6
AMV 132M CA	4/2	1.9/8.0	2.6/10.9	1450/2930	12.5/26.1	83.7/88.0	0.82/0.87	4.0/15.1	4.0/16.0	5.5/7.0	2.2/3.0	17.13	51.4
AMV 160M AA	4/2	2.8/11	3.8/15.0	1440/2940	18.6/35.7	82.5/88.2	0.78/0.90	6.3/20.0	7.0/20.4	5.0/7.5	2.0/2.1	51.75	94
AMV 160M BA	4/2	3.3/13.5 <sup>1)</sup>	4.5/18.3 <sup>1)</sup>	1440/2920	21.9/44.2	83.0/88.5	0.80/0.92	7.2/24.0	7.5/24.0	5.5/7.5	2.0/2.2	51.75	94
AMV 160L CA	4/2	4.4/18.5 <sup>1)</sup>	6.0/25.1 <sup>1)</sup>	1450/2940	29/60.1	85.5/89.5	0.83/0.92	9.0/32.5	9.5/33.0	5.5/7.5	2.0/2.2	64.0	108.7
750/1500 min <sup>-1</sup> (8/4 poles) - Dahlander connection Y/YY													
AMV 71Z AA	8/4	0.08/0.37	0.11/0.5	660/1370	1.2/2.6	26/57	0.63/0.72	0.60/1.25	0.65/1.35	2.8/3.4	1.9/1.7	1.24	6.8
AMV 80Z AA	8/4	0.12/0.55	0.16/0.75	685/1420	1.7/3.7	50/69	0.60/0.74	0.58/1.53	0.65/1.6	1.9/3.3	1.4/1.5	2.47	9.2
AMV 80Z BA	8/4	0.18/0.75	0.25/1.0	660/1380	2.6/5.2	53/67	0.73/0.81	0.65/1.9	0.7/2.0	2.0/3.5	1.6/1.7	2.41	10.6
AMV 90L AA	8/4	0.18/1.1	0.25/1.5	680/1400	2.5/7.5	60/70	0.65/0.82	0.9/2.7	1.0/2.8	2.8/4.0	1.5/2.0	2.98	15.7
AMV 90L CA	8/4	0.4/1.6	0.54/2.15	675/1400	5.7/10.9	61.5/75	0.64/0.79	1.8/4.0	1.8/4.1	3.1/5.0	1.6/2.2	3.70	19.6
AMV 100L AA	8/4	0.45/2.2	0.60/3.0	680/1420	6.3/14.8	63.1/75.3	0.60/0.80	1.7/5.0	1.9/5.3	2.7/4.7	1.7/2.0	5.58	21.9
AMV 100L BA	8/4	0.6/2.6	0.80/3.5	680/1435	8.4/17.3	64.0/76.2	0.63/0.75	2.2/6.5	2.3/6.7	2.7/4.8	1.7/2.2	6.00	23.7
AMV 112M AA	8/4	0.7/3.3	0.94/4.5	690/1420	9.7/22.2	62/78	0.70/0.80	2.2/7.4	2.3/7.6	3.4/6.5	1.8/2.4	16.70	34.2
AMV 112M CA	8/4	1.0/4.0	1.34/5.5	720/1420	13.3/26.9	60/77	0.70/0.82	3.1/8.6	3.3/9.0	3.5/5.0	2.3/1.9	19.50	40.0
AMV 132S AA	8/4	1.1/4.5	1.5/6.1	725/1450	14.5/29.6	77.0/85.5	0.58/0.82	3.6/9.3	4.0/9.7	3.5/5.4	2.2/2.7	22.4	41.9
AMV 132M BA	8/4	1.4/5.5	1.9/7.5	720/1440	18.6/36.5	78.0/86.0	0.62/0.82	4.2/11.3	4.5/12	3.6/5.5	2.0/2.5	29.25	51.0
AMV 132M CA	8/4	1.8/7.5	2.4/10.2	720/1450	23.9/49.4	78.2/86.5	0.64/0.86	5.2/14.6	5.5/15.0	4.6/6.0	2.0/2.5	37.25	65.0
AMV 160M ZA	8/4	2.2/10.0	3.0/13.0	720/1450	29.2/65.9	80.0/88.0	0.61/0.83	6.6/19.9	6.8/20.4	3.5/6.0	1.8/1.7	81.25	88.5
AMV 160L ZA	8/4	3.2/15.0 <sup>1)</sup>	4.3/20.0 <sup>1)</sup>	720/1450	42.4/98.8	81.0/90.0	0.61/0.88	9.4/27.3	9.8/28	3.5/6.5	1.7/1.8	105.75	106.5

1) Temperature rise to class F

# THREE-PHASE TWO SPEED MOTORS FOR CENTRIFUGAL MACHINES

DESIGNED FOR RANGE  
OF RATED VOLTAGE  
380-420 V ± 5% - 50 HZ

FOR MAINS VOLTAGE  
400 V - 50 HZ

TEMPERATURE RISE TO CLASS B

Type	kW	HP	min <sup>-1</sup>	M <sub>N</sub> Nm	η 100%	cos φ	I <sub>N</sub>		I <sub>A</sub> /I <sub>N</sub>	M <sub>A</sub> /M <sub>N</sub>	J		
							400V	380-420V			10 <sup>-3</sup> kgm <sup>2</sup>	kg	
1500/1000 min <sup>-1</sup> (4/6 poles) - separate windings													
AMV 71Z AA	4/6	0.25/0.08	0.33/0.11	1370/900	1.7/0.4	60/40	0.80/0.70	0.75/0.4	0.8/0.45	3.0/2.5	1.6/1.6	1.15	6.7
AMV 71Z BA	4/6	0.37/0.13	0.50/0.18	1360/880	2.6/1.4	62/44	0.80/0.70	1.0/0.6	1.1/0.7	3.2/2.6	1.6/1.6	1.24	7.2
AMV 80Z AA	4/6	0.55/0.18	0.75/0.25	1380/920	3.8/1.9	60/42	0.83/0.82	1.60/0.75	1.7/0.8	3.5/2.4	1.6/1.0	1.97	8.3
AMV 80Z BA	4/6	0.75/0.25	1.0/0.33	1400/940	5.1/2.5	70/60	0.82/0.72	1.8/0.8	1.9/0.9	4.2/2.6	1.6/1.3	4.05	14
AMV 90S AA	4/6	0.75/0.24	1.0/0.32	1400/950	5.1/2.4	70/60	0.82/0.72	1.9/0.8	2.0/0.9	4.2/2.6	1.6/1.3	4.05	14
AMV 90L BA	4/6	1.1/0.37	1.5/0.50	1400/930	7.5/3.8	70/60	0.81/0.74	2.8/1.2	3.0/1.3	4.3/2.7	1.6/1.2	4.78	16.4
AMV 90L CA	4/6	1.5/0.5	2.0/0.67	1420/950	10.1/5	73/64	0.80/0.70	3.52/1.52	3.7/1.6	4.8/2.6	1.5/1.3	5.98	20.5
AMV 100L AA	4/6	1.85/0.60	2.5/0.75	1400/920	12.6/6.2	74/64	0.80/0.73	4.6/1.9	4.8/2.1	4.8/3.1	1.8/1.5	6.73	23.4
AMV 100L BA	4/6	2.2/0.75	3.0/1.0	1420/950	14.8/7.5	76/66	0.79/0.75	5.1/2.1	5.3/2.2	5.0/3.5	1.7/1.3	9.25	22.6
AMV 112M AA	4/6	3/1.0	4.0/1.34	1440/970	19.9/9.8	80/73	0.81/0.65	6.6/3.0	6.8/3.2	5.8/4.6	2.5/2.1	13.3	30.4
AMV 132S AA	4/6	3.8/1.3	5.2/1.8	1460/970	24.9/12.8	85.0/75.0	0.8/0.72	8.1/3.5	8.5/4	6.5/4.0	2.2/1.7	22.4	41.9
AMV 132M BA	4/6	4.4/1.5	6.0/2.0	1460/970	28.8/14.8	86.0/78.2	0.85/0.73	8.7/3.8	9.2/4.3	6.5/4.4	2.2/1.7	29.25	51.0
AMV 132M CA	4/6	5.5/1.8	7.5/2.4	1460/970	36/17.7	86.8/80.0	0.84/0.74	10.9/4.4	12.0/4	7.0/4.7	2.6/1.8	37.25	65.0
AMV 132M DA	4/6	6.3/2.2 <sup>1)</sup>	8.6/3.0 <sup>1)</sup>	1460/970	41.2/21.7	86.8/81.0	0.84/0.73	12.5/5.4	13.5/5	7.2/4.8	2.6/1.9	37.25	66.0
AMV 160M AA	4/6	7.5/2.5	10.0/3.4	1470/975	48.7/24.5	87.5/83.0	0.83/0.75	14.9/5.8	15.6/6.0	8.3/4.5	2.5/1.9	81.25	88.5
AMV 160L BA	4/6	11.0/3.7	15.0/5.0	1470/970	71.5/36.4	88.0/84.2	0.81/0.73	22.5/8.7	23.4/9.0	8.0/4.8	2.4/1.8	105.75	106.5
AMV 160L CA	4/6	13.0/4.0 <sup>1)</sup>	17.7/5.4 <sup>1)</sup>	1460/970	85/39.4	88.0/84.5	0.81/0.72	26.3/9.5	27.5/10	8.0/4.8	2.4/1.9	105.75	106.5

Type	kW	HP	min <sup>-1</sup>	M <sub>N</sub> Nm	η 100%	cos φ	I <sub>N</sub>		I <sub>A</sub> /I <sub>N</sub>	M <sub>A</sub> /M <sub>N</sub>	J		
							400V	380-420V			10 <sup>-3</sup> kgm <sup>2</sup>	kg	
1000/750 min <sup>-1</sup> (6/8 poles) - separate windings													
AMV 80Z AA	6/8	0.25/0.11	0.33/0.15	930/720	2.6/1.5	53/49	0.79/0.62	0.9/0.55	1.0/0.7	2.9/3.0	1.6/1.8	1.97	7.9
AMV 80Z BA	6/8	0.37/0.15	0.50/0.25	920/715	3.8/2	52/47	0.81/0.63	1.3/0.8	1.4/0.9	2.8/2.8	1.4/1.9	2.47	9.5
AMV 90L AA	6/8	0.55/0.22	0.75/0.30	960/740	5.5/2.8	65/47	0.62/0.51	2.0/1.4	2.1/1.5	3.9/2.9	2.5/2.1	4.78	16.2
AMV 90L BA	6/8	0.75/0.30	1.0/0.40	940/720	7.6/4	64/45.5	0.67/0.52	2.5/1.85	2.7/1.9	3.4/2.6	2.2/1.9	4.78	16.2
AMV 100L AA	6/8	1.1/0.45	1.5/0.60	950/710	11.1/6.1	70.6/58	0.71/0.67	3.1/1.7	3.3/1.8	4.3/2.8	2.0/1.3	9.43	22.0
AMV 112M AA	6/8	1.5/0.6	2.0/0.80	970/720	14.8/8	75.8/65	0.65/0.60	4.4/2.3	3.7/2.5	5.5/3.4	2.8/2.1	18.70	39.0
AMV 132S ZA	6/8	2.2/0.9	3.0/1.2	970/715	21.7/12	78.0/69.0	0.67/0.55	6.1/3.5	6.7/4.0	4.8/4.0	1.6/1.6	29.5	42.5
AMV 132M YA	6/8	3/1.2	4.0/1.6	960/715	29.8/16	80/72	0.7/0.55	7.8/4.4	8.2/4.8	4.8/4.1	1.6/1.6	37.75	55.5
AMV 132M ZA	6/8	4/1.6	5.5/2.2	960/715	39.8/21.4	81.0/74.0	0.78/0.6	9.2/5.2	9.8/5.6	5.3/4.4	1.7/1.7	44.5	64.1
AMV 160M YA	6/8	5.5/2.2	7.5/3.0	970/730	54.1/28.8	83/76	0.77/0.6	12.5/7	13.5/7.5	5.7/5.6	1.6/1.9	112.7	88.0
AMV 160M ZA	6/8	7/3	9.5/4.1	970/730	68.9/39.2	84/77	0.80/0.65	15/8.7	16/9.3	6.0/5.8	1.7/2.2	150.25	97.5

1) Temperature rise to class F